



TYPICAL

GC9 SERIES

TWIN NEEDLE LOCK STITCHER
INSTRUCTION BOOK
PARTS CATALOGUE

Thank you very much for buying our company's sewing machine. Before using your new machine, please read the safety instructions below and the explanations given in the instruction manual.

With industrial sewing machines, it is normal to carry out work while positioned directly in front of moving parts such as the needle and thread take-up lever, and consequently there is always a danger of injury that can be caused by these parts. Follow the instructions from training personnel and instructors regarding safe and correct operation before operating the machine so that you will know how to use it correctly.

SAFETY INSTRUCTIONS

1. Safety indications and their meanings

This instruction manual and the indications and symbols that are used on the machine itself are provided in order to ensure safe operation of this machine and to prevent accidents and injury to yourself or other people. The meaning of these indications and symbols are given below.

Indications



The instructions which follow this term indicate situations where failure to follow the instructions could cause injury when using the machine or physical damage to equipment and surroundings.

Symbols



This symbol () indicates something that you should be careful of. The picture inside the triangle indicates the nature of the caution that must be taken.

(For example, the symbol at left means "beware of injury".)



This symbol () indicates something that you must not do.



This symbol () indicates something that you must do. The picture inside the circle indicates the nature of the thing that must be done.

(For example, the symbol at left means "you must make the ground connection".)

2. Notes on safety



CAUTION

Environmental requirements



Use the sewing machine in an area which is free from sources of strong electrical noise such as electrical line noise or static electric noise. Sources of strong electrical noise may cause problems with correct operation.



The ambient temperature should be within the range of 5°C to 35°C during use. Temperatures which are lower or higher than this may cause problems with correct operation.



Any fluctuations in the power supply voltage should be within $\pm 10\%$ of the rated voltage for the machine. Voltage fluctuations which are greater than this may cause problems with correct operation.



The relative humidity should be within the range of 45% to 85% during use, and no dew formation should occur in any devices. Excessively dry or humid environments and dew formation may cause problems with correct operation.



The power supply capacity should be greater than the requirements for the sewing machine's power consumption. Insufficient power supply capacity may cause problems with correct operation.



In the event of an electrical storm, turn off the power and disconnect the power cord from the wall outlet. Lightning may cause problems with correct operation.

Installation



Machine installation should only be carried out by a qualified technician.



All cords should be secured at least 25 mm away from any moving parts. Furthermore, do not excessively bend the cords or secure them too firmly with staples, otherwise there is the danger that fire or electric shocks could occur.



Contact your dealer or a qualified electrician for any electrical work that may need to be done.



The sewing machine weighs approximately 43 kg. The installation should be carried out by two or more people.



If using a work table which has casters, the casters should be secured in such a way so that they cannot move.



Do not connect the power cord until installation is complete. The machine may operate if the treadle is depressed by mistake, which could result in injury.



Use both hands to hold the machine head when tilting it back or returning it to its original position. If only one hand is used, the weight of the machine head may cause your hand to slip, and your hand may get caught.



Be sure to connect the ground. If the ground connection is not secure, you run a high risk of receiving a serious electric shock, and problems with correct operation may also occur.



Be sure to wear protective goggles and gloves when handling the lubricating oil and grease, so that they do not get into your eyes or onto your skin, otherwise inflammation can result. Furthermore, do not drink the oil or eat the grease under any circumstances, as they can cause vomiting and diarrhea. Keep the oil out of the reach of children.



CAUTION

Sewing



The sewing machine should only be used by operators who have received the necessary training in safe use beforehand.



Attach all safety devices before using the sewing machine. If the machine is used without these devices attached, injury may result.



The sewing machine should not be used for any applications other than sewing.



Do not touch any of the moving parts or press any objects against the machine while sewing, as this may result in personal injury or damage to the machine.



Be sure to wear protective goggles when using the machine.

If goggles are not worn, there is the danger that if a needle breaks, parts of the broken needle may enter your eyes and injury may result.



Use both hands to hold the machine head when tilting it back or returning it to its original position. If only one hand is used, the weight of the machine head may cause your hand to slip, and your hand may get caught.



Turn off the power switch at the following times.

The motor will keep turning even after the power is switched off as a result of the motor's inertia. Wait until the motor stops fully before starting work. The machine may operate if the treadle is depressed by mistake, which could result in injury.

- When threading the needle
- When replacing the bobbin and needle
- When not using the machine and when leaving the machine unattended.



If an error occurs in machine, or if abnormal noises or smells are noticed, immediately turn off the power switch. Then contact your nearest dealer or a qualified technician.



If the machine develops a problem, contact your nearest dealer or a qualified technician.



If using a work table which has casters, the casters should be secured in such a way so that they cannot move.

Cleaning



Turn off the power switch before carrying out cleaning. The motor will keep turning even after the power is switched off as a result of the motor's inertia. Wait until the motor stops fully before starting work. The machine may operate if the treadle is depressed by mistake, which could result in injury.



Be sure to wear protective goggles and gloves when handling the lubricating oil and grease, so that they do not get into your eyes or onto your skin, otherwise inflammation can result. Furthermore, do not drink the oil or eat the grease under any circumstances, as they can cause vomiting and diarrhea.

Keep the oil out of the reach of children.



Use both hands to hold the machine head when tilting it back or returning it to its original position. If only one hand is used, the weight of the machine head may cause your hand to slip, and your hand may get caught.

3. Warning labels

The following warning labels appear on the sewing machine.

Please follow the instructions on the labels at all times when using the machine. If the labels have been removed or are difficult to read, please contact your nearest dealer.

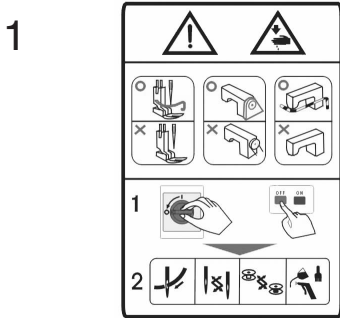

Be sure to connect the ground. If the ground connection is not secure, you run a high risk of receiving a serious electric shock, and problems with correct operation may also occur.

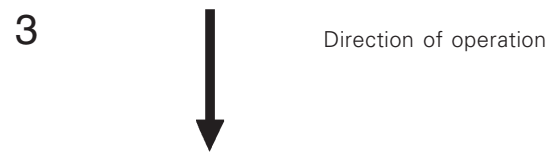

safety devices:

- (A) Finger guard
- (B) Thread take – up cover
- (C) Belt cover

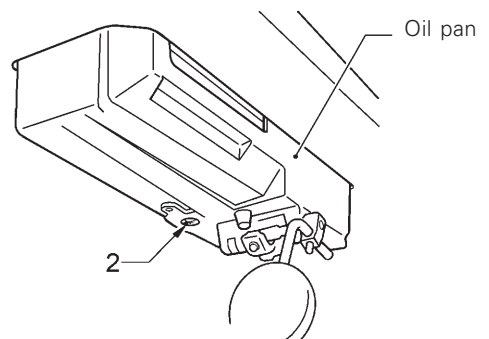
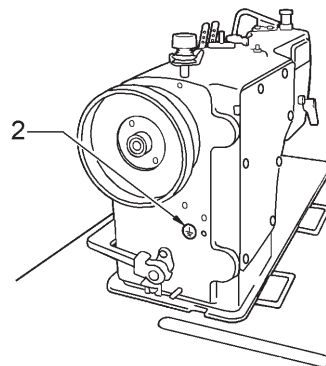
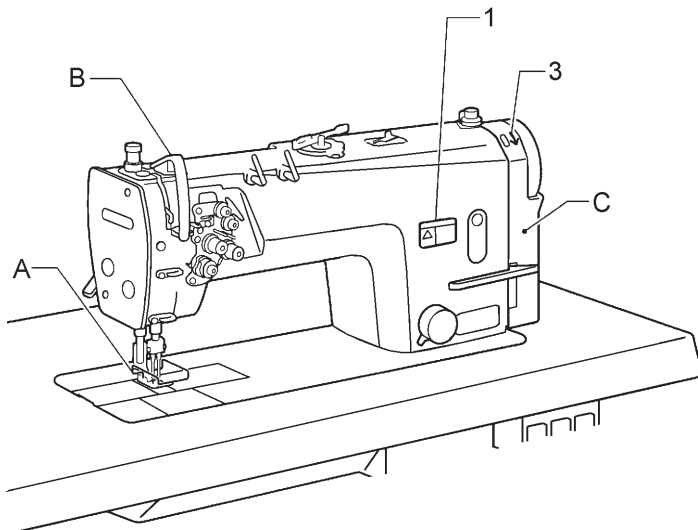

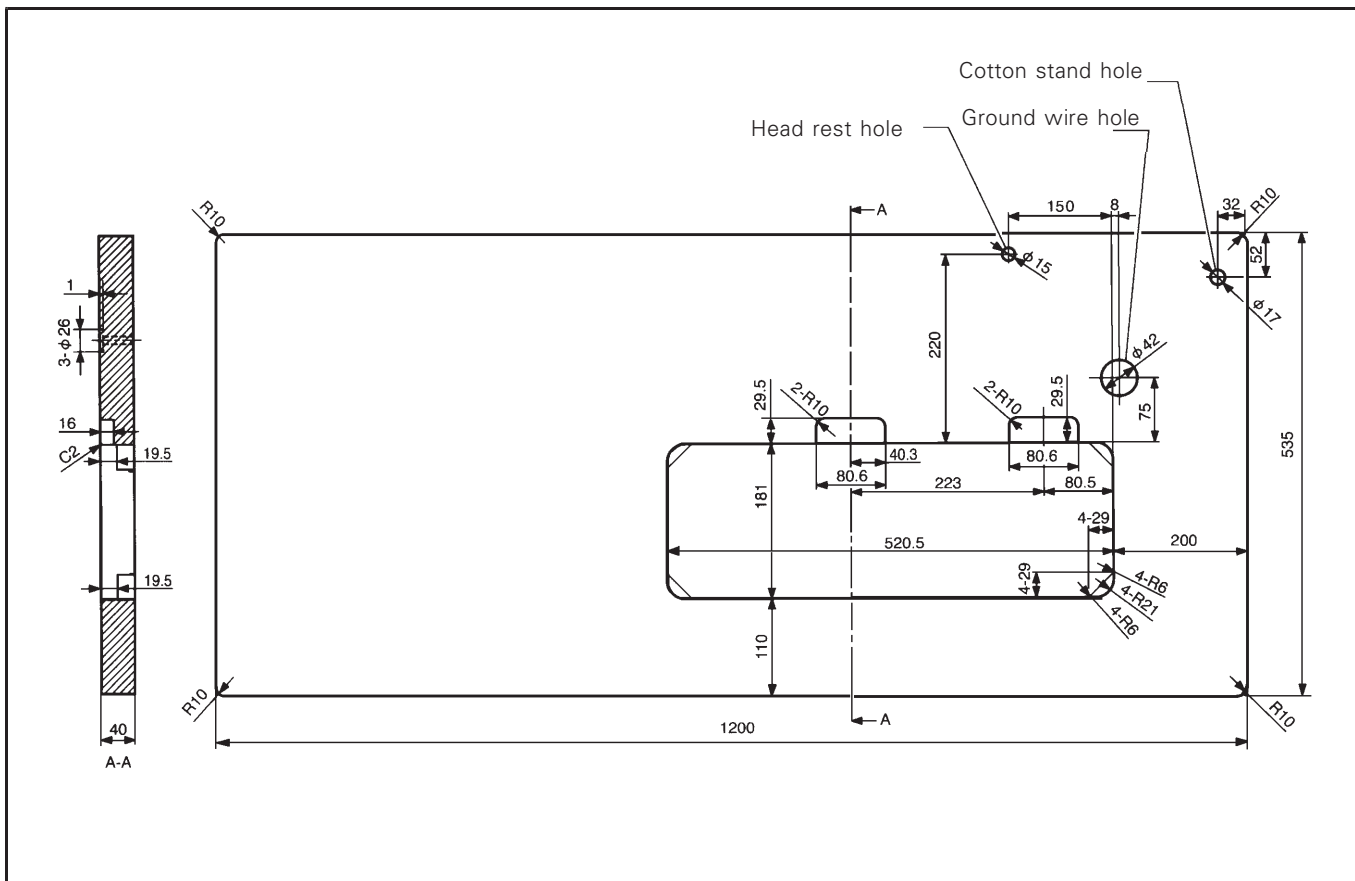

Motor



CAUTION



All cords should be secured at least 25 mm away from any moving parts. Furthermore, do not excessively bend the cords or secure them too firmly with staples, otherwise there is the danger that fire or electric shocks could occur.



<Motor>

● Use one of the clutch motors given in the table at right as the motor.

● Refer to the instruction manual for the motor for details on installing and using the motor.

Power	Motor
Single-phase	2-pole 400wmoter
Single-phase	2-pole 400wmoter

<Motor pulley and V-belt>

select the correct motor pulley and V-belt by referring to the table below to suit the power frequency of your area.

Sewing speed	Frequency	Motor pulley Outer diameter	V-belt
4,000rpm	50Hz	90	43
	60Hz	75	42
3,500rpm	50Hz	80	42
	60Hz	60	42
3,000rpm	50Hz	65	42
	60Hz	55	41

3.INSTALLATION



CAUTION



Machine installation should only be carried out by a qualified technician.



Contact your dealer or a qualified electrician for any electrical work that may need to be done.



The sewing machine weighs approximately 43kg. The installation should be carried out by two or more people.



Do not connect the power cord until installation is complete. The machine may operate if the treadle is depressed by mistake, which could result in injury.



Use both hands to hold the machine head when tilting it back or returning it to its original position. If only one hand is used, the weight of the machine head may cause your hand to slip, and your hand may get caught.



Be sure to connect the ground. If the ground connection is not secure, you run a high risk of receiving a serious electric shock, and problems with correct operation may also occur.

Carrying the machine

- The machine should be carried by the arm by two people as shown in the illustration.
- * Make sure that the machine pulley does not turn.

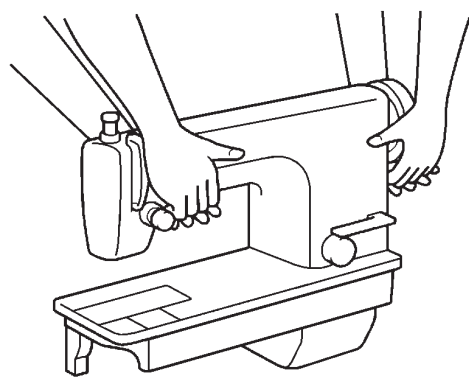

Tilting back the machine head

- Hold section (B) with your foot so that the table does not move, and then push the arm with both hands to tilt back the machine head.

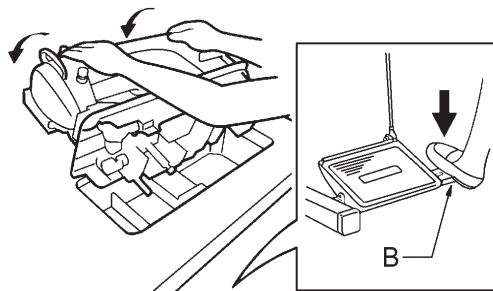

Returning the machine head to the upright position

1. Clear away any tools, etc. which may be near the table holes.
2. While holding the face plate with your left hand, gently return the machine head to the upright position with your right hand.

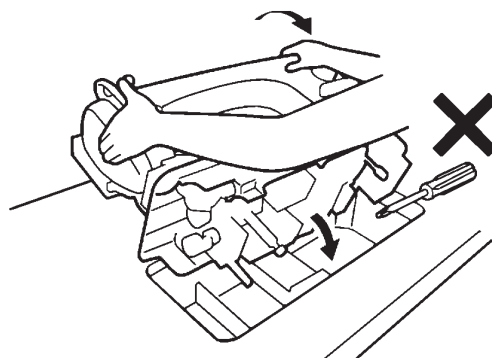

3-1. Installation

1. Oil pan

- (1)Head cushions (left) [2 pcs]
- (2)Head cushions (right) [2 pcs]
- (3)Oil pan.
- (4)Oiler

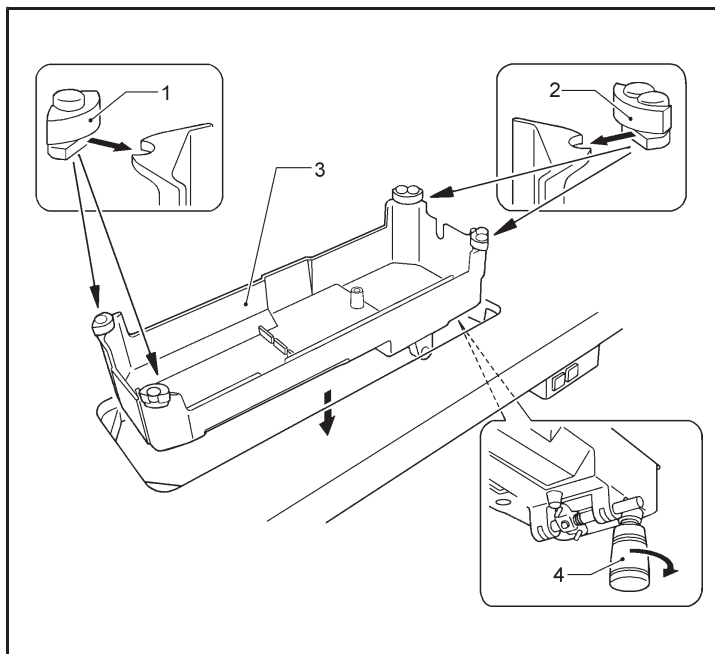

2. Rubber cushions

- (1)Rubber cushions [2 pcs]

3. Knee lifter complying bar

- (2)Knee lifter complying bar

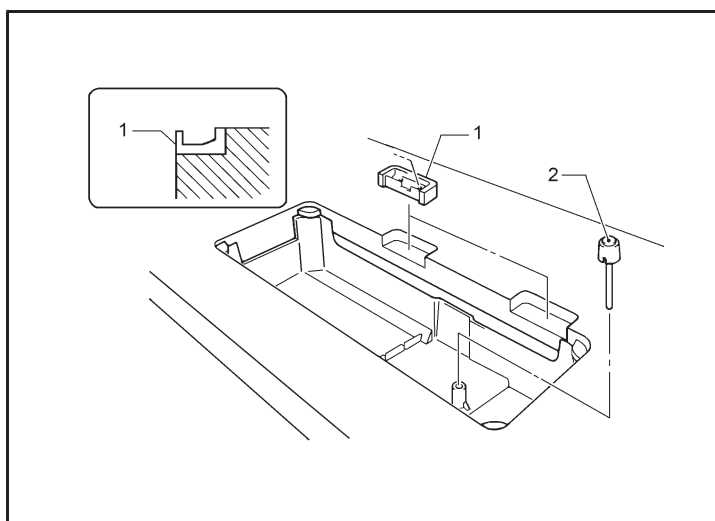

4. Machine head

- (1) Hinges [2 pcs]
- (2) Machine head
- (3) Head rest

NOTE:

Tap the head rest (3) securely into the table hole. If the head rest (3) is not pushed in as far as it will go, the machine head will not be sufficiently stable when it is tilted back.

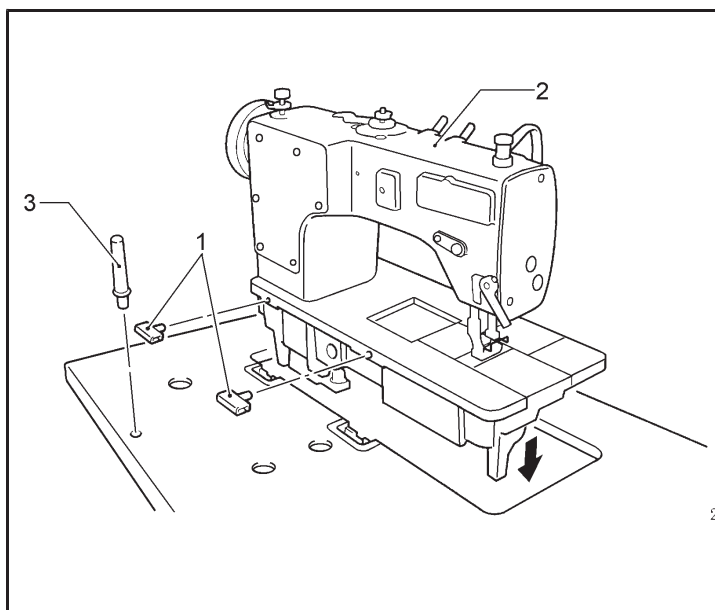

5. Knee lifter plate

(1) Knee lifter plate

(2) Bolt

* Loosen the bolt (3) and the bolt (4), and move the knee lifter plate (1) to a position where it is easy to use.

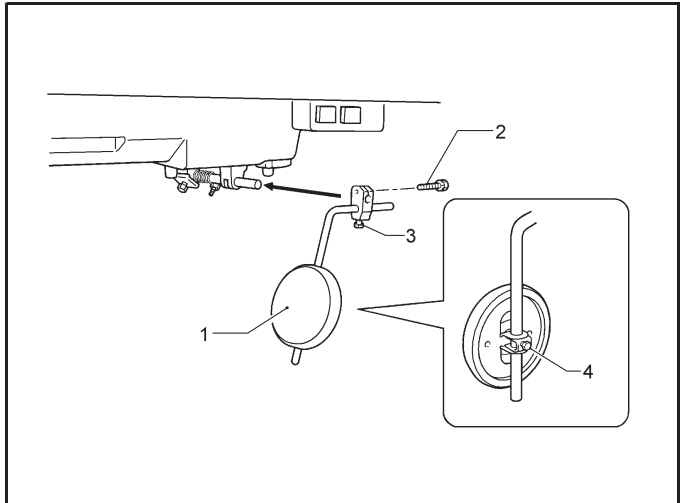

<Knee lifter adjustment>

1. Turn the machine pulley so that the feed dog is below the top of the needle plate.
2. Lower the presser foot (5) by using the lifting lever (4).

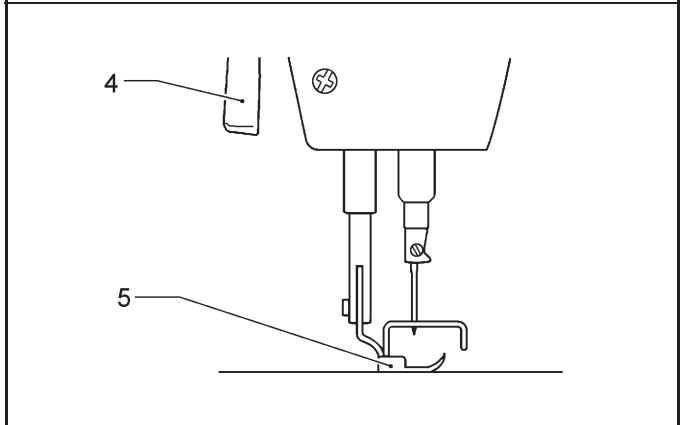

3. Loosen the nut (6).
4. Turn the screw (8) to adjust so that the amount of play in the knee lifter (7) is approximately 2 mm when the knee lifter plate (1) is gently pressed.
5. Securely tighten the nut (6)
6. Loosen the nut (9)
7. Turn the screw (10) until the distance between the end of the screw (10) and the knee lifter (7) is approximately 5 mm.
8. Turn the adjusting screw (10) to adjust so that the presser foot (5) is at the desired position within a distance of 13 mm of the needle plate when the knee lifter plate (1) is fully pressed.
9. After adjustment is completed, securely tighten the nut (9)

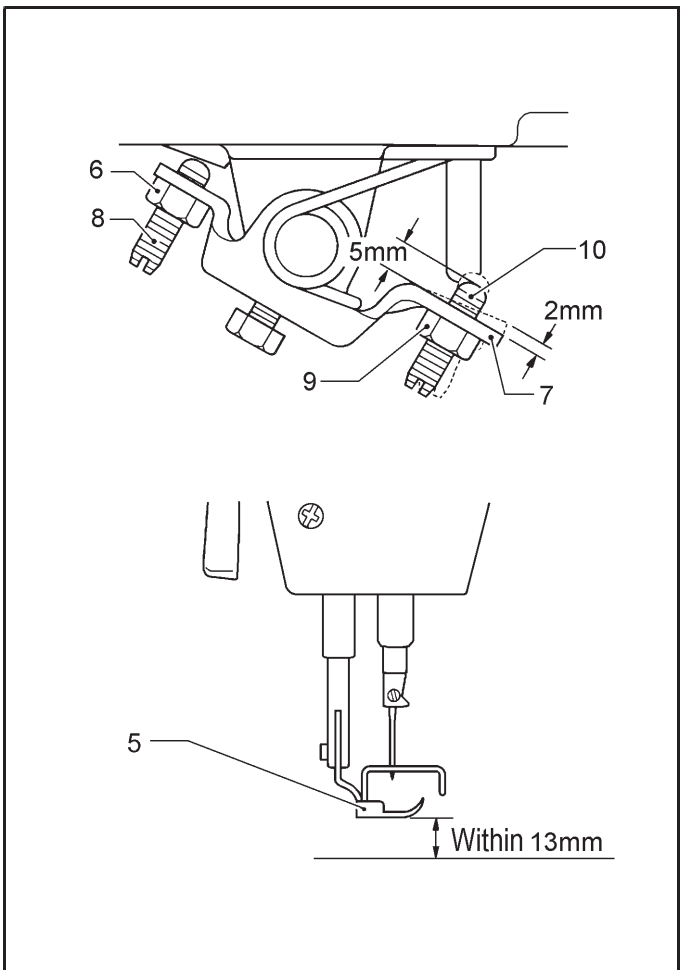

6. Ground wire
 (1) Ground wire
 (2) Screw

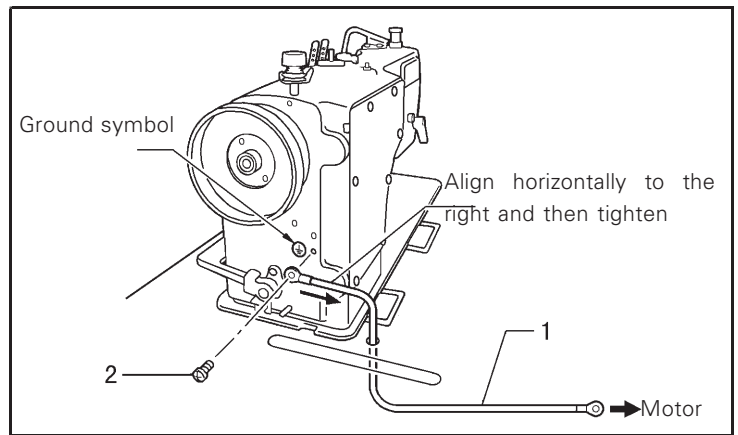

7. Ground wire
 Use a suitable ground wire
 (1) Ground wire
 (2) Screw

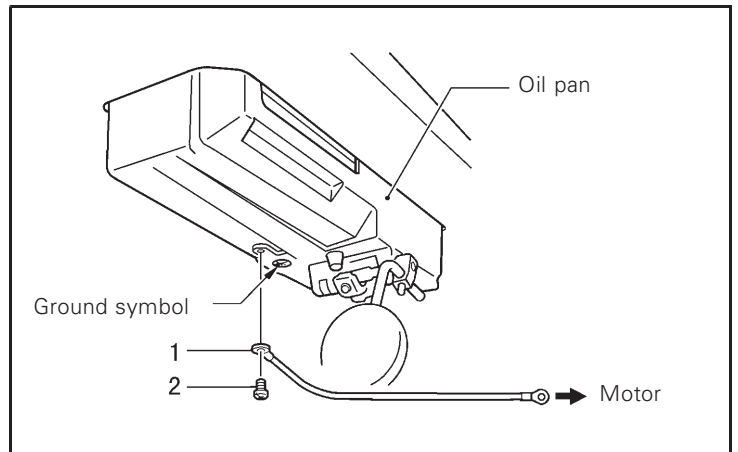

8. V-belt
 (1) V-belt
 Turn the two nuts (2) to adjust so that there is 10–14 mm of deflection in the V-belt (1) when it is pressed at the midway point with a force of 5 N.

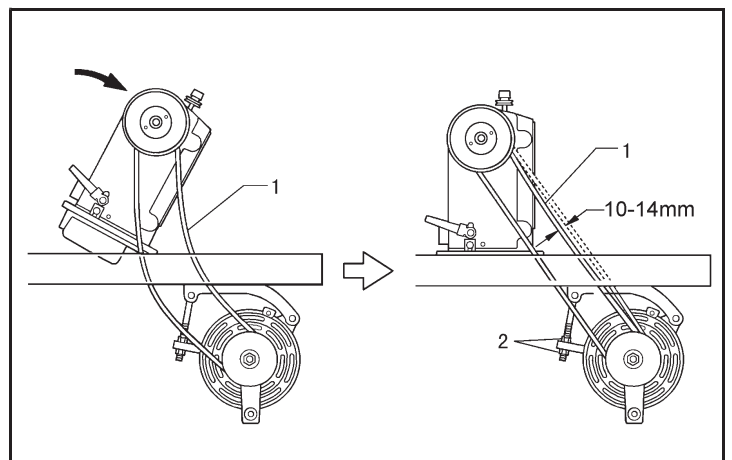

9. Belt cover bracket
 (1) Belt cover bracket
 (2) Screws [2 pcs]

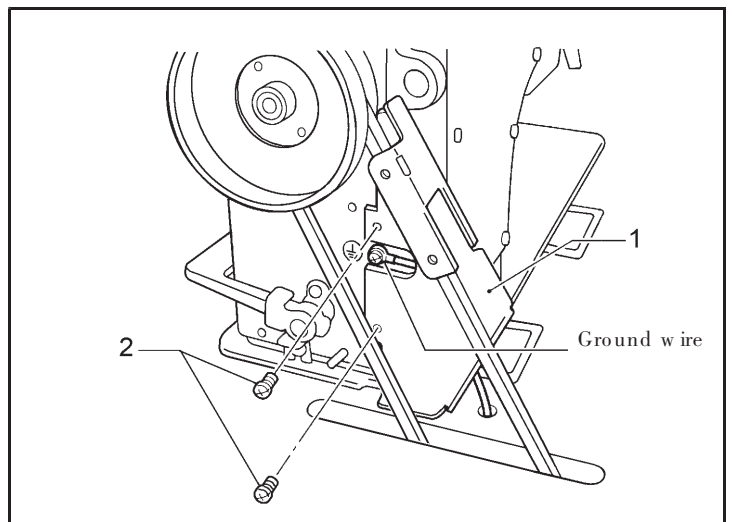

- 10. Belt cover U
- (1) Belt cover U
- (2) Screws [4 pcs]

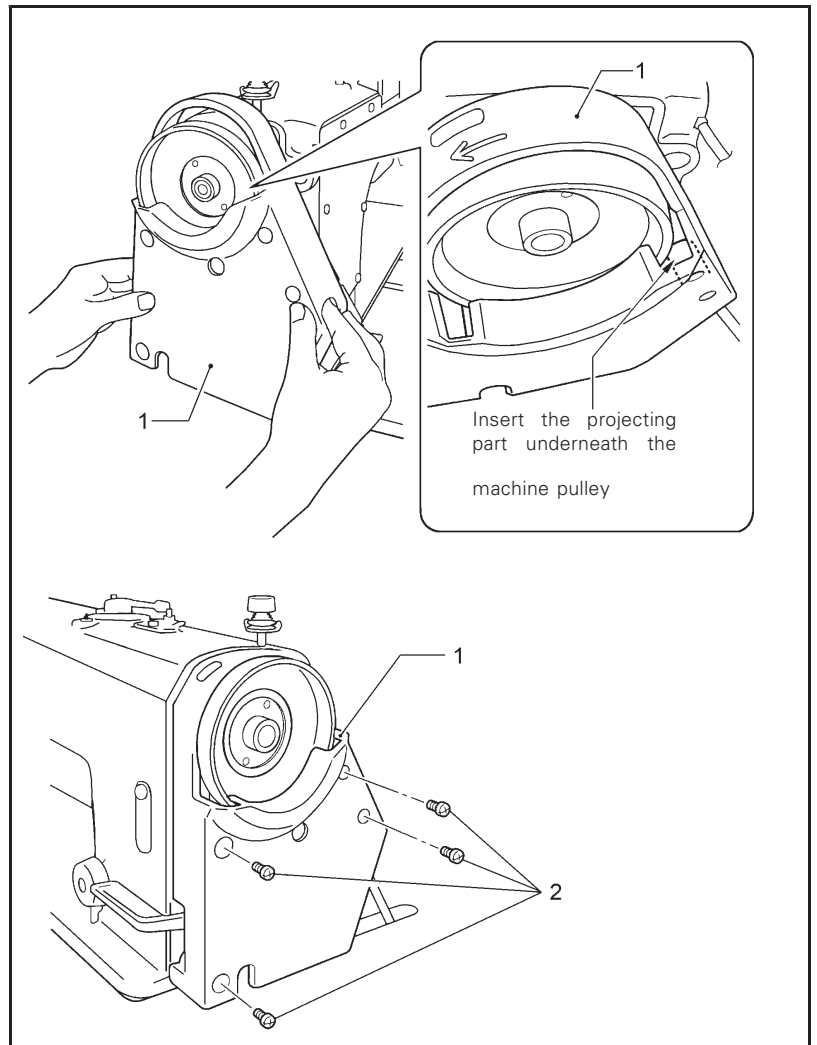

- 11. Belt cover D
- (1) Belt cover D
- (2) Wood screws [2 pcs]

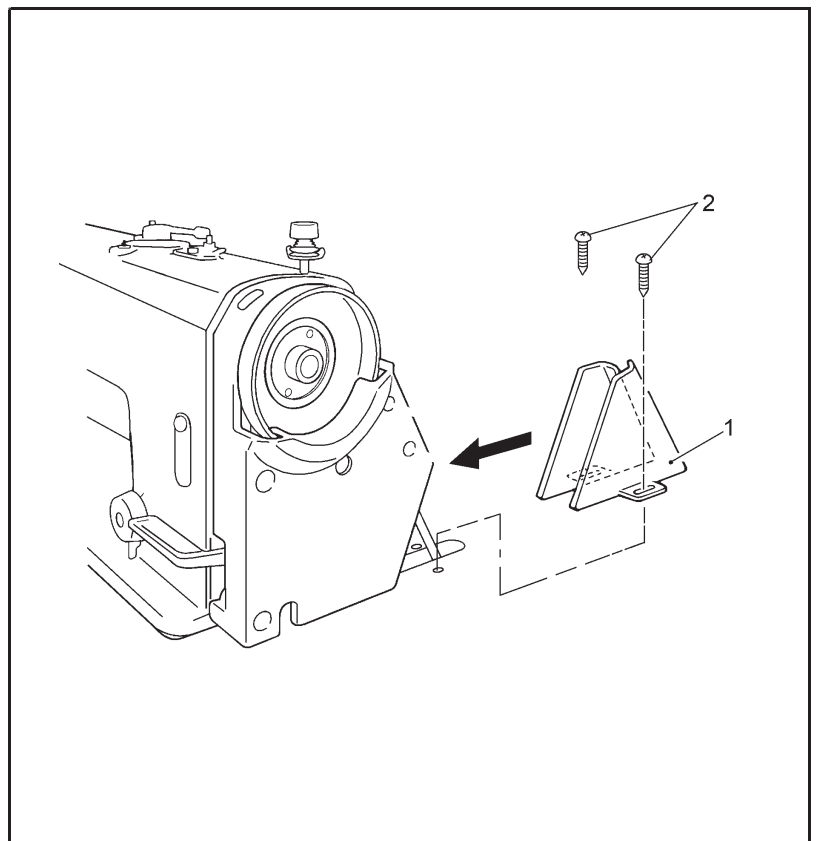

- 12. Belt cover D lid
- (1) Belt cover D lid

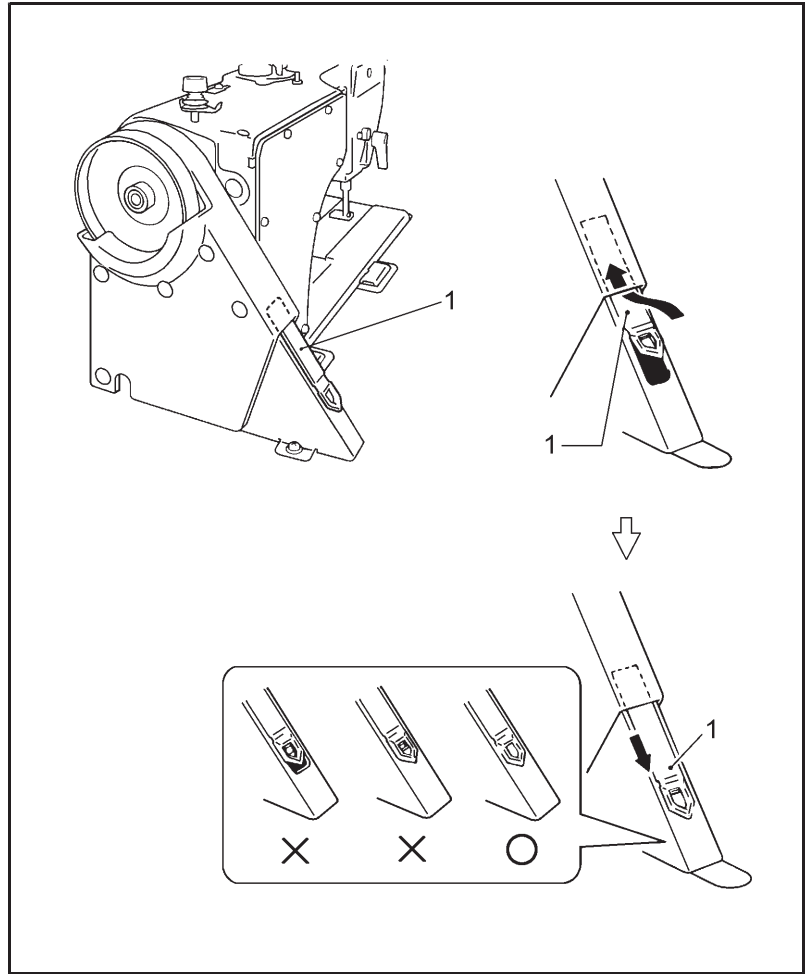

Pull belt cover D (2) forward to adjust so that there is no gap between belt cover U (3) and the belt cover D lid (1).

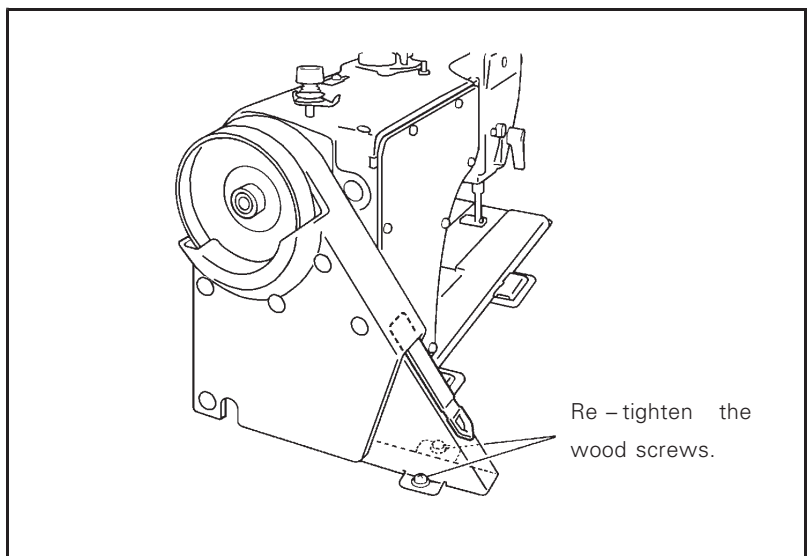
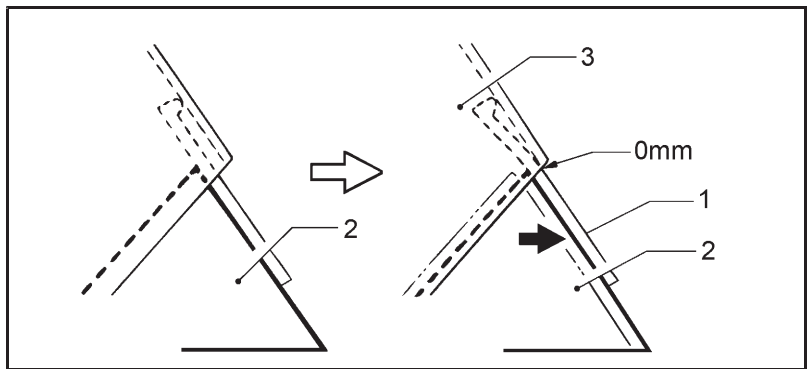

13. Cotton stand

(1) Cotton stand

NOTE:

Securely tighten the nut (4) so that the two rubber cushions (2) and the washer (3) are securely clamped and so that the cotton stand (1) does not move.

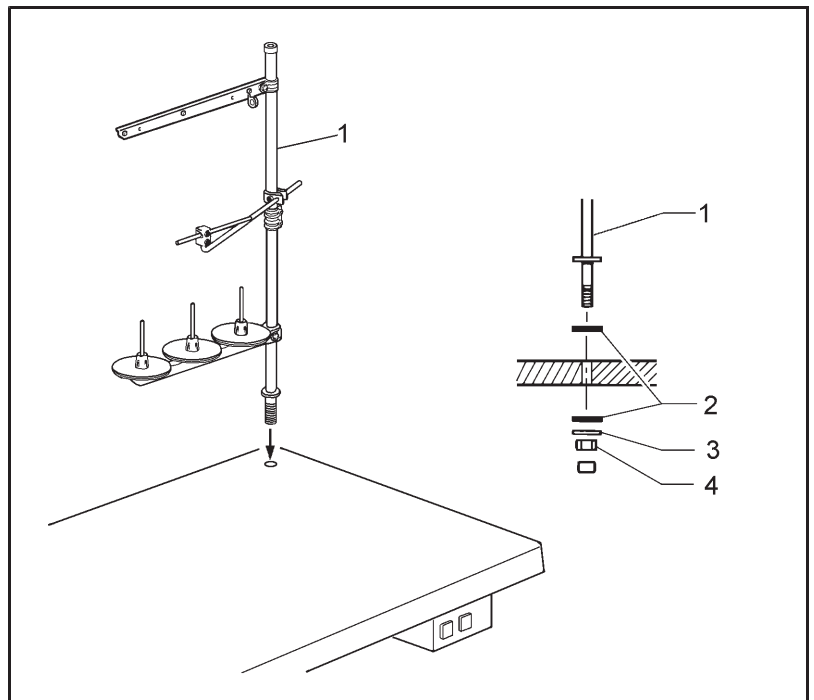



3-2. Lubrication



CAUTION

 Do not connect the power cord until lubrication has been completed, otherwise the machine may operate if the treadle is depressed by mistake, which could result in injury.

 Be sure to wear protective goggles and gloves when handling the lubricating oil and grease, so that they do not get into your eyes or onto your skin, otherwise inflammation can result.

 Furthermore, do not drink the oil or eat the grease under any circumstances, as they can cause vomiting and diarrhea. Keep the oil out of the reach of children.

● The sewing machine should always be lubricated and the oil supply replenished before it is used for the first time, and also after long periods of non-use.

● Use only the lubricating oil specified by our company.

<Lubricating via the oil cover>

1. Tilt back the machine head
2. Remove the rubber cap (1),
3. Use the accessory oiler (2) to pour lubricating oil into the oil cover (3) until the oil level reaches the reference line (4).

NOTE:

Do not fill with lubricating oil past the reference line (4). If you pour in too much lubricating oil, it may spill out when the machine head is tilted back.

4. Replace the rubber cap (1)
 5. Return the machine head to its original position.
- * If the lubricating oil level drops below the bottom (6) of the oil gauge window (5), be sure to add more oil.

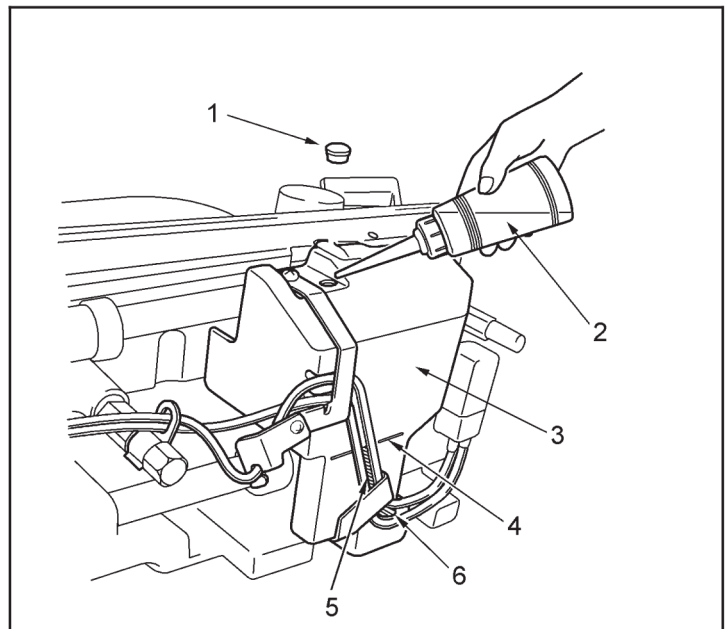

<Lubricating via the oil tank>

1. Remove the rubber cap (1).
 2. Use the accessory oiler (2) to pour in lubricating oil until the oil level reaches the top reference line (4) of the oil gauge window (3).
 3. Replace the rubber cap (1).
- * If the lubricating oil level drops below the bottom reference line (5), be sure to add more oil.

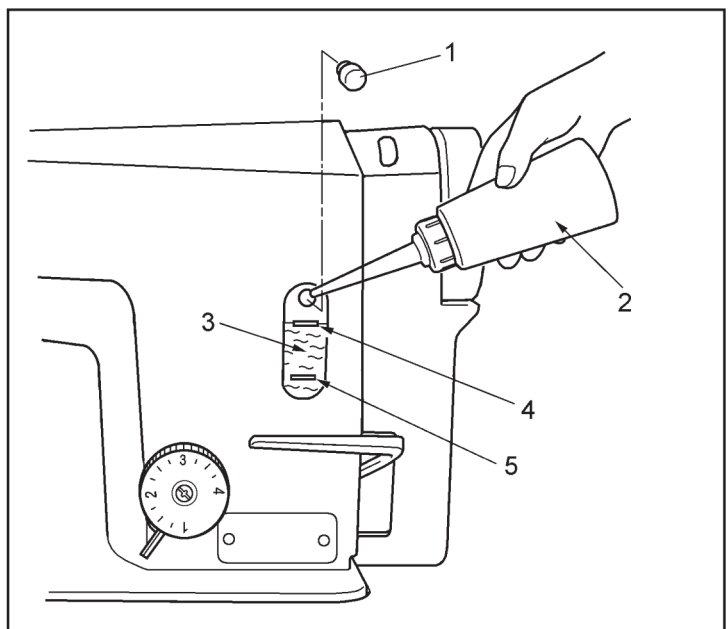

Lubrication

Apply 1–2 drops of oil to the places indicated by the arrows.

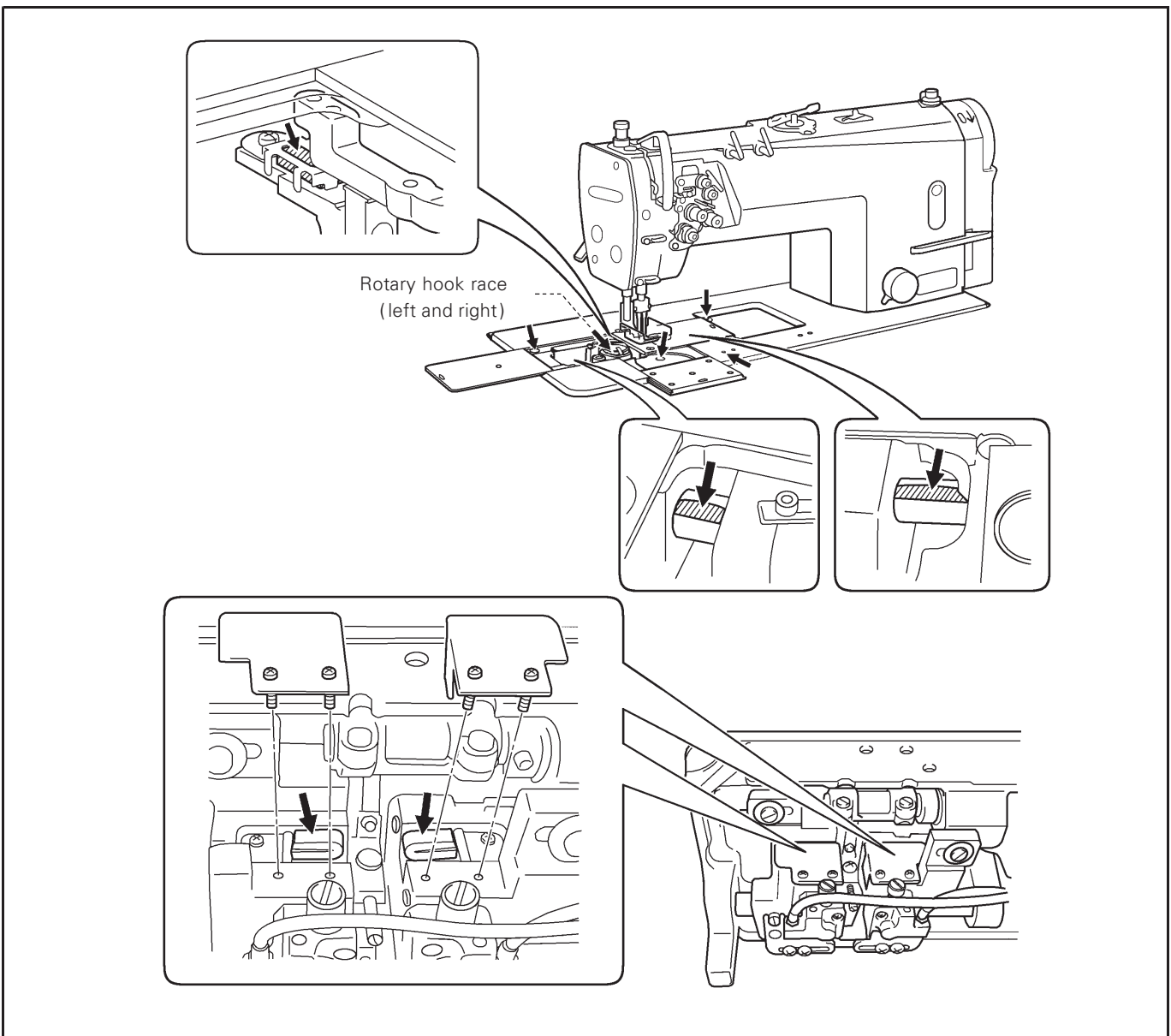
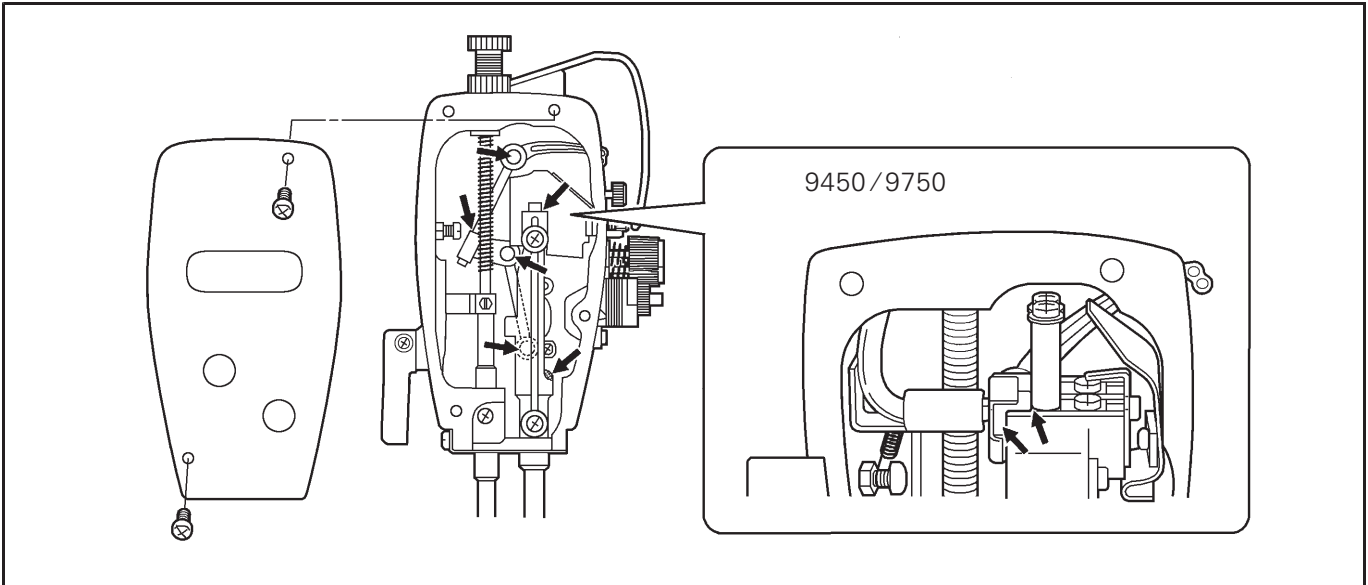

3-3 Checking the machine pulley rotating direction



CAUTION



Do not touch any of the moving parts or press any objects against the machine while sewing, as this may result in personal injury or damage the machine.

1. Insert the power cord plug into the wall outlet, and then turn on the power switch.
 2. Depress the treadle slightly and check that the machine pulley starts to turn in the direction of the arrow (1).
- * If the direction of rotation is reversed, change the direction of rotation to the correct direction while referring to the in-struction manual for the motor.

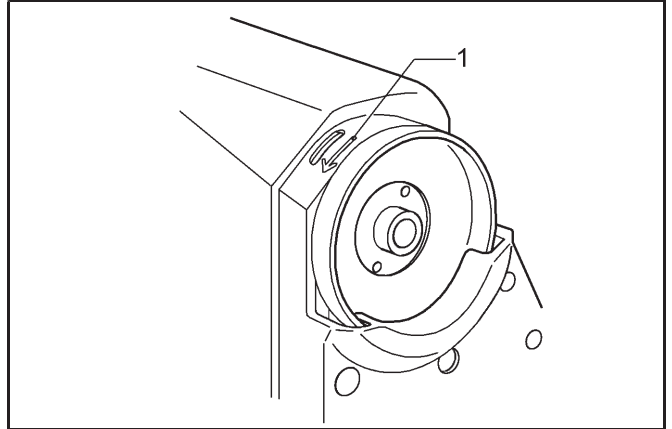

4. PREPARATION BEFORE SEWING

4-1. Installing the needle



CAUTION



Turn off the power switch before installing the needle. The motor will keep turning even after the power is switched off as a result of the motor's inertia. Wait until the motor stops fully before starting work. The machine may operate if the treadle is depressed by mistake, which could result in injury.

1. Turn the machine pulley to move the needle bar to its highest position.
2. Loosen the screw (1).
3. Insert the needle (2) straight in as far as it will go so that the long groove is facing inward, and then securely tighten the screws (1).

GC9420 GC9720

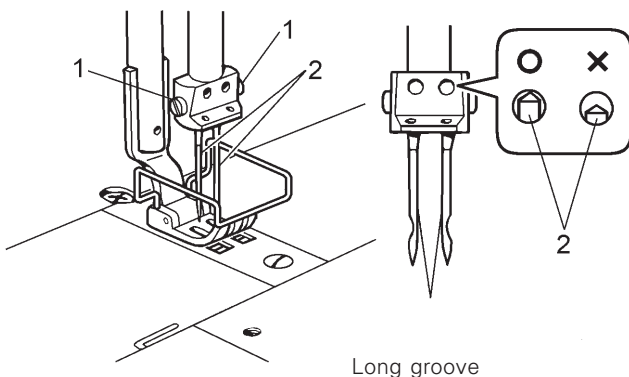

Long groove

GC9450 GC9750

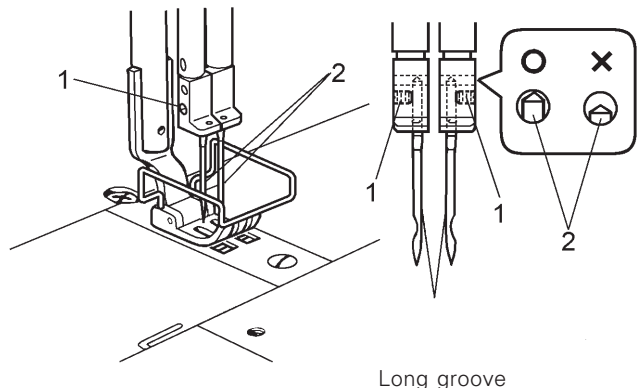

Long groove

4-2. Removing the bobbin



CAUTION



Turn off the power switch before removing the bobbin. The motor will keep turning even after the power is switched off as a result of the motor's inertia. Wait until the motor stops fully before starting work. The machine may operate if the treadle is depressed by mistake, which could result in injury .

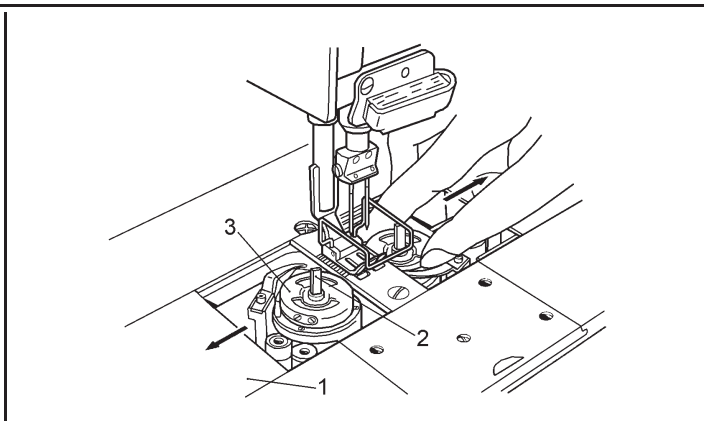
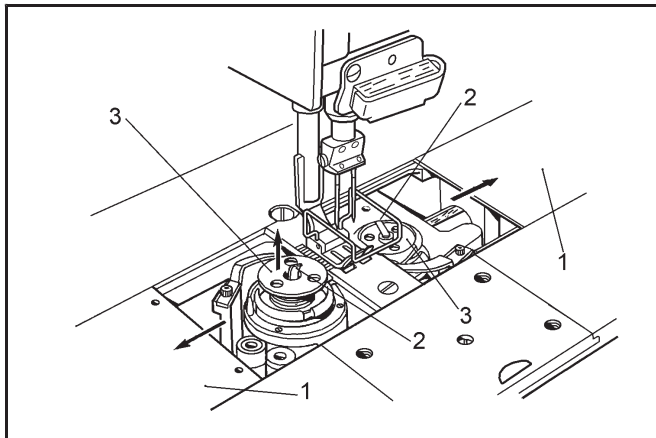

<Latch type>

1. Open the slide plates (1) by moving them to the right and left.
2. Pull the rotary hook latches (2) upward, and then remove the bobbins (3).

<Bobbin case type>

1. Open the slide plates (1) by moving them to the right and left.
2. Lift up the latch (2) of the rotary hook,, and then remove the bobbin case (3).
3. Remove the bobbin.

4-3. Winding the lower thread



CAUTION



Do not touch any of the moving parts or press any objects against the machine while winding the lower thread, as this may result in personal injury or damage to the machine.

1. Turn on the power switch.
2. Place the bobbin (1) onto the bobbin winder shaft (2).
3. Wind the thread several times around the bobbin (1) in the direction indicated by the arrow.
- * Check that the thread is not loose anywhere along the thread path.
4. Push the bobbin presser arm (3) toward the bobbin (1).
5. Raise the presser foot with the lifting lever.
6. Depress the treadle. Lower thread winding will then start.
7. Once winding of the lower thread is completed, the bobbin presser arm (3) will return automatically.
8. After the thread has been wound on, remove the bobbin and cut the thread with the knife (4).

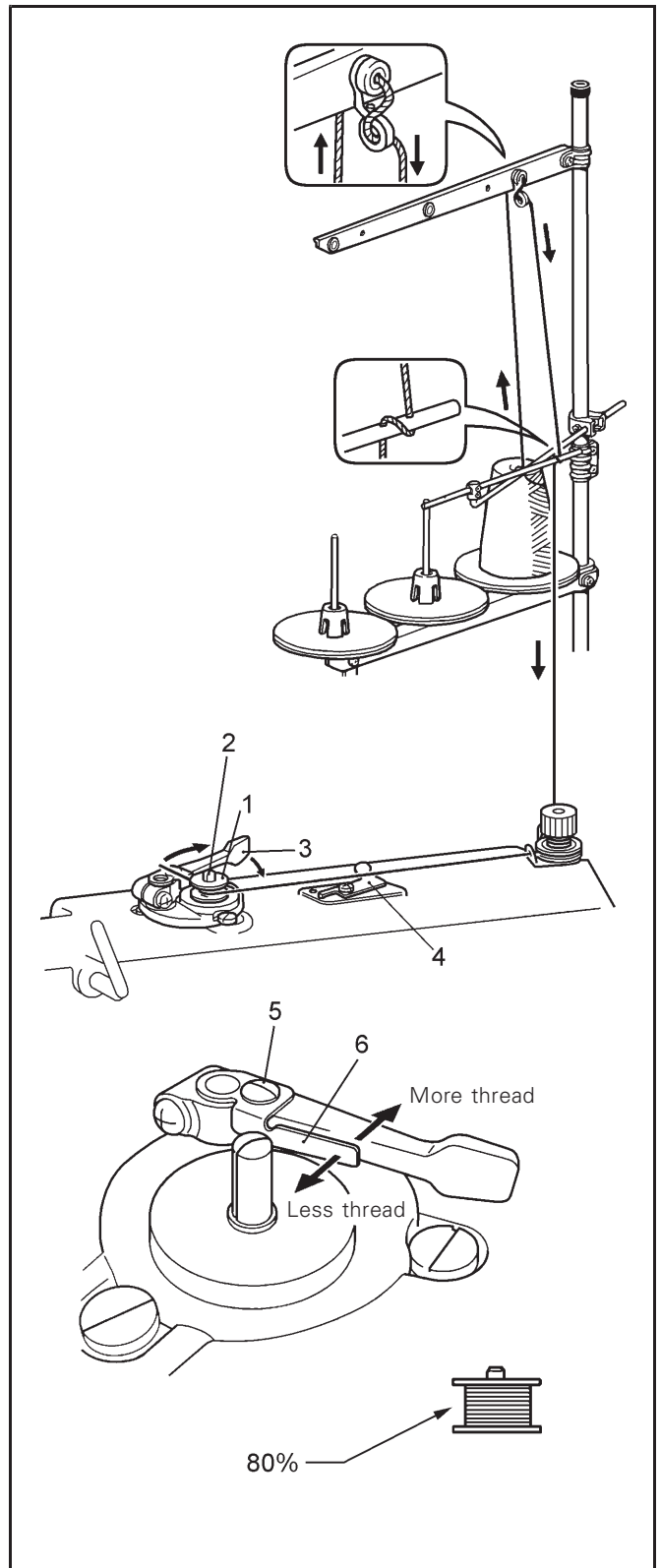

* Loosen the screw (5) and move the bobbin presser (6) to adjust the amount of thread wound onto the bobbin.

NOTE:

The amount of thread wound onto the bobbin should be a maximum of 80% of the bobbin capacity.

4-4 Installing the bobbin



CAUTION



Turn off the power switch before installing the bobbin. The motor will keep turning even after the power is switched off as a result of the motor's inertia. Wait until the motor stops fully before starting work. The machine may operate if the treadle is depressed by mistake, which could result in injury.

(Latch type)

1. Insert the bobbin (1) into the rotary hook (2) so that the winding direction is as shown in the illustration.
2. Return the rotary hook latch (3) to its original position.
3. Turn the machine pulley to rotate the rotary hook (2) until the tension spring (4) is visible.
4. Pass the thread through slit (5) in the rotary hook and then pass it under the thread tension spring.
5. Pull out the thread to a length of approximately 50 mm.
6. Close the slide plates.

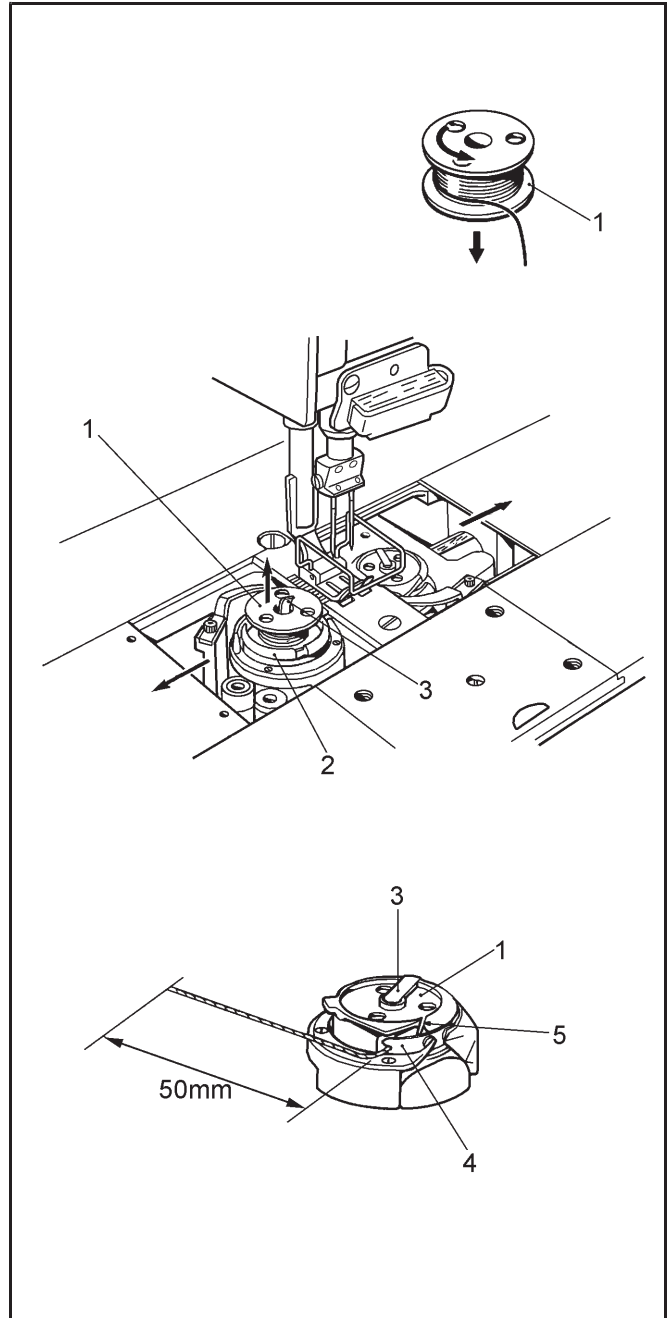

<Bobbin case type>

1. Insert the bobbin (1) into the bobbin case (2) so that the winding direction is as shown in the illustration.
2. There are three types of cap (2)<A>,and<C>). Thread the thread by one of the following methods in accordance with the shape of the bobbin case (2) being used.

<A>

- 1) Pass the thread through slot (3) and under the thread tension spring (4).
- 2) Pass the thread through the thread hole (5) and pull out about 50 mm.

<C>

- 1) Pass the thread through slot (3) and under the thread tension spring (4).
- 2) Pass the thread through slots (5) and (6), and then through the spring (7).
- 3) Pass the thread through the thread hole (8) and pull out about 50 mm.
3. Insert the bobbin case (2) into the rotary hook.
4. Push latch (9) of the rotary hook flat.
5. Close the slide plates.

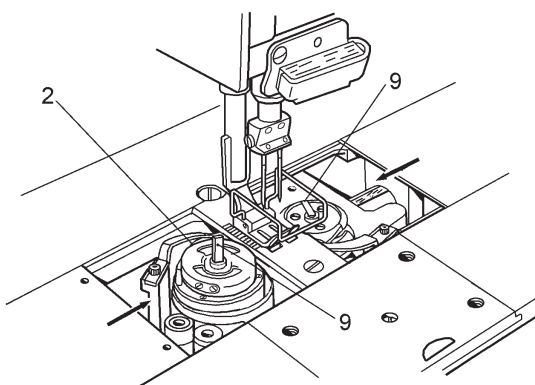
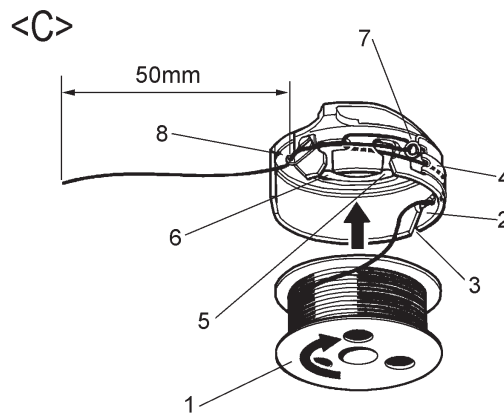
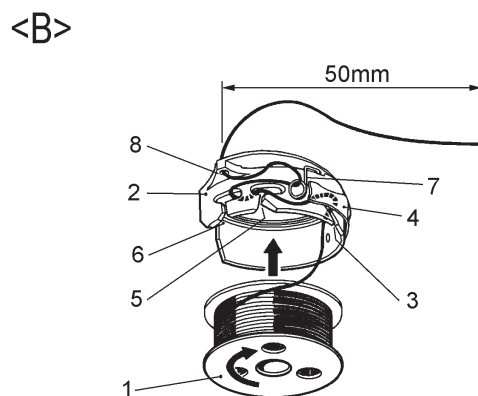
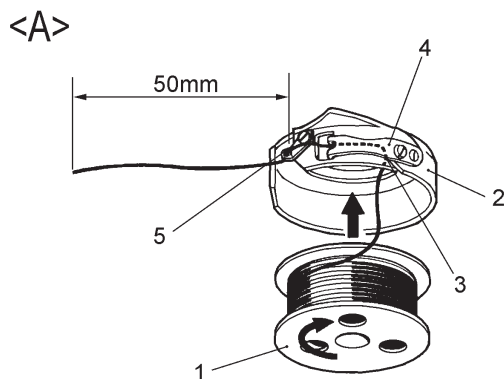

4-5 Threading the upper thread



CAUTION



Turn off the power switch before threading the upper thread. The motor will keep turning even after the power is switched off as a result of the motor's inertia. Wait until the motor stops fully before starting work. The machine may operate if the treadle is depressed by mistake. Which could result in injury.

- Turn the machine pulley and raise the thread take-up (1) before threading the upper thread. This will make threading easier and it will prevent the thread from coming out at the sewing start.
- Thread the left-side thread first.

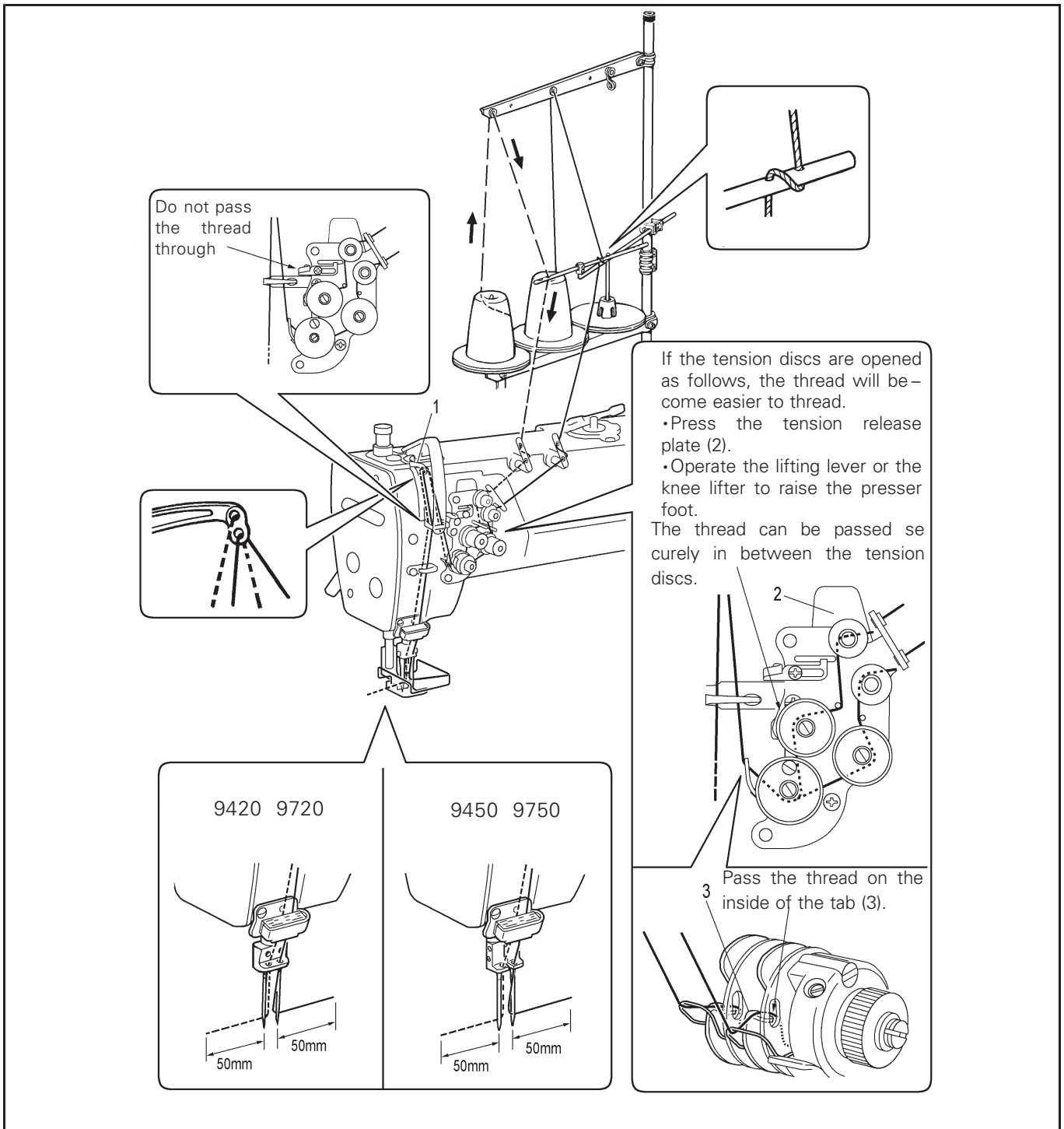

4-6 Adjusting the stitch length

1. Unlock the stitch length dial (2) by turning the dial lock lever (1) to the right until a click is heard.
 2. Turn the stitch length dial (2) clockwise or counter clockwise so that the desired stitch length is at the uppermost position on the dial.
- The larger the number, the longer the stitch length will be. (The numbers on the dial are for use as a guide. The length of the finished stitches may vary depending on the type and thickness of material being sewn. Adjust while looking at the finished stitches.)
 - When turning the stitch length dial (2) from a larger setting to a smaller setting, it will be easier to turn the dial if the reverse lever (3) is pushed to the halfway down position.
3. Turn the dial lock lever (1) firmly to the left to lock the stitch length dial (2).
- * Check that the stitch length dial (2) does not rotate.

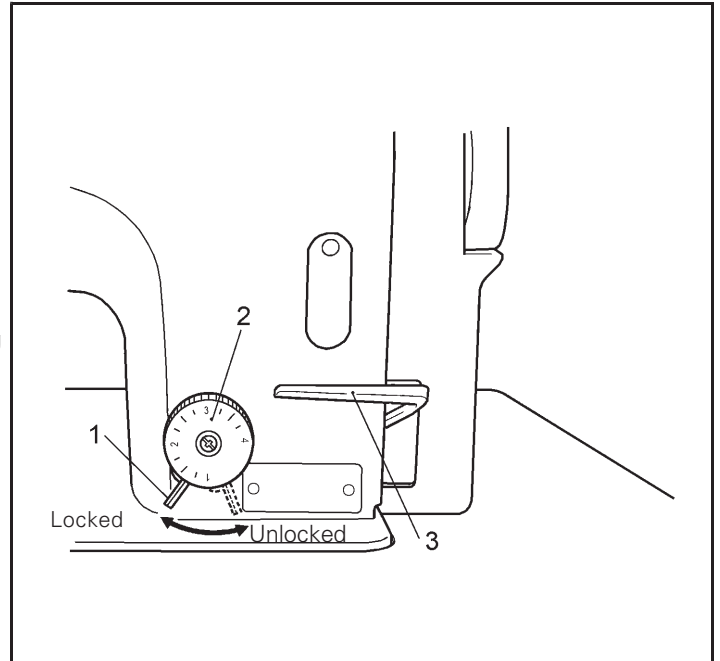

4-7. Using the knee lifter

The presser foot (2) can be raised by pressing the knee lifter plate (1).

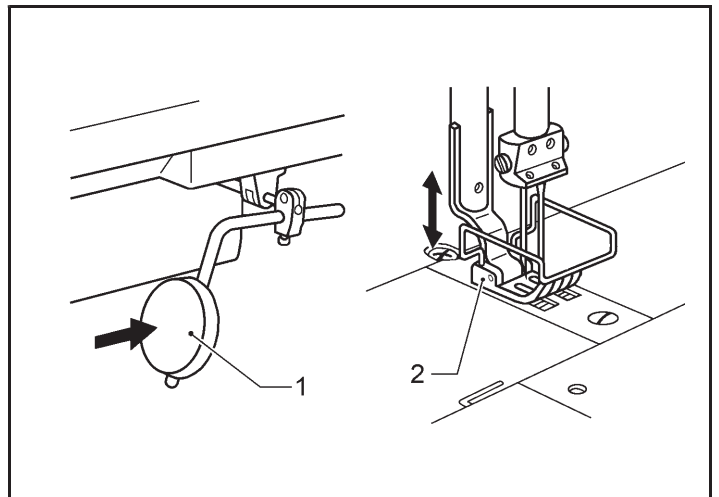

4-8. Corner sewing method (9450,9750)

NOTE: If using this machine in place of a single-needle machine, remove the needle which is not being used. In such cases, do not use the procedures given below to stop the unused needle bar from moving, otherwise damage to the machine may result.

4-8-1. To stop the needle bars (right and left)

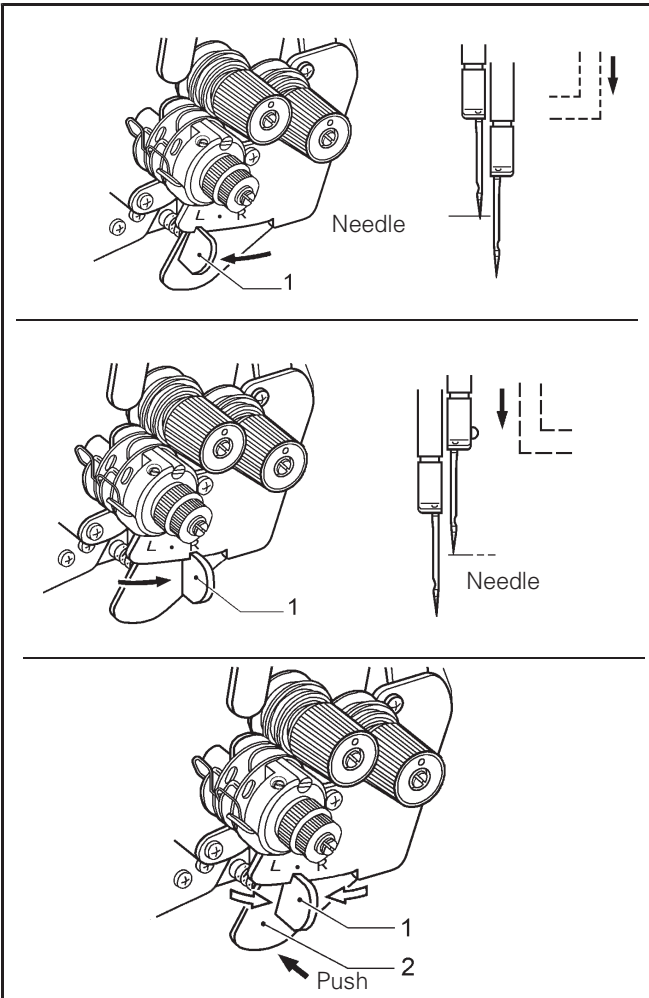

- Operate the stop lever after the needle has penetrated the material and has stopped moving.
- Do not sew at speeds of over 1,000 rpm while one of the needle bars has been stopped.

<To stop operation of the left needle bar>
Move the stop lever (1) to the "L" position.

<To stop operation of the right needle bar>
Move the stop lever (1) to the "R" position.

<To resume twin-needle sewing >
Press the push lever (2).
The stop lever (1) will then return to its original position automatically.

4-8-2. Number of stitches: quick-reference guide

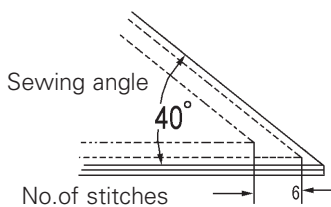

sewing angle No. of Stitches	sewing angle											
	30	40	50	60	70	80	90	100	110	120	130	140
2					4.6	3.8	3.2	2.7	2.2	1.8	1.5	1.1
3			4.6	3.5	3.0	2.5	2.1	1.8	1.5	1.2		
4		4.4	3.4	2.8	2.3	1.9	1.6	1.3				
5	4.8	3.5	2.7	2.2	1.8	1.5	1.3					
6	4.0	2.9	2.3	1.9	1.5	1.3						
7	3.7	2.5	2.0	1.6								
8	3.0	2.2	1.7									

<For "1/4" needle width>

Determine the stitch length from the chart above to make beautiful corner stitching.

The number of stitches of the outer needle varies according to the combination of sewing angle and stitch length.

[Example]

For a sewing angle of 40° and a stitch length of 2.9 mm, the number of stitches becomes 6.

5. SEWING



CANTION



Attach all safety devices before using the sewing machine. If the machine is used without these devices attached, injury may result.



Turn off the power switch at the following times. The motor will keep turning even after the power is switched off as a result of the motor's inertia. Wait until the motor stops fully before starting work.

The machine may operate if the treadle is depressed by mistake, which could result in injury.

- When threading the needle.
- When replacing the bobbin and needle
- When not using the machine and when leaving the machine unattended.



Do not touch any of the moving parts or press any objects against the machine while sewing, as this may result in personal injury or damage to the machine.



Use both hands to hold the machine head when tilting it back or returning it to its original position. If only one hand is used, the weight of the machine head may cause your hand to slip, and your hand may get caught.

5-1. Sewing

1. While holding the two upper threads with your fingers, turn the machine pulley by hand toward you until the lower threads come out onto the feed dog.
2. Pull the lower threads toward you and check that they pull out smoothly.
3. Turn on the power switch..
4. Depress the treadle to start sewing.

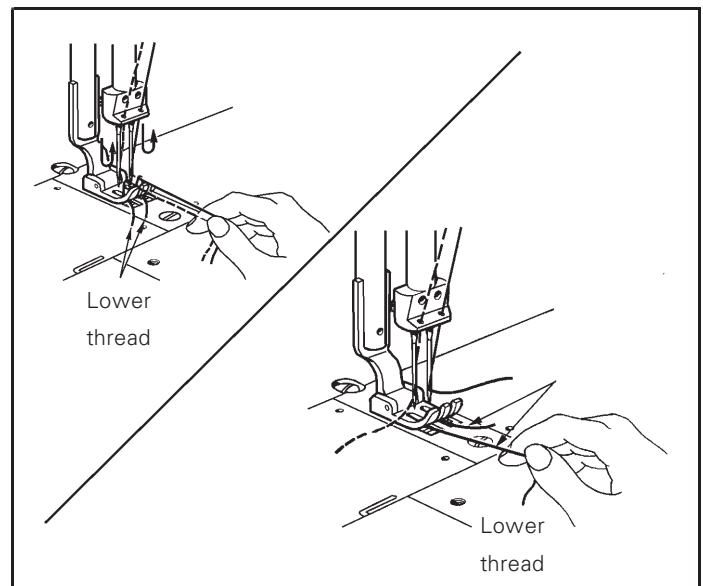

5-2. Backtacking

When the reverse lever (1) is pressed during sewing, the feed direction will be reversed. When it is released, the feed direction will return to normal.

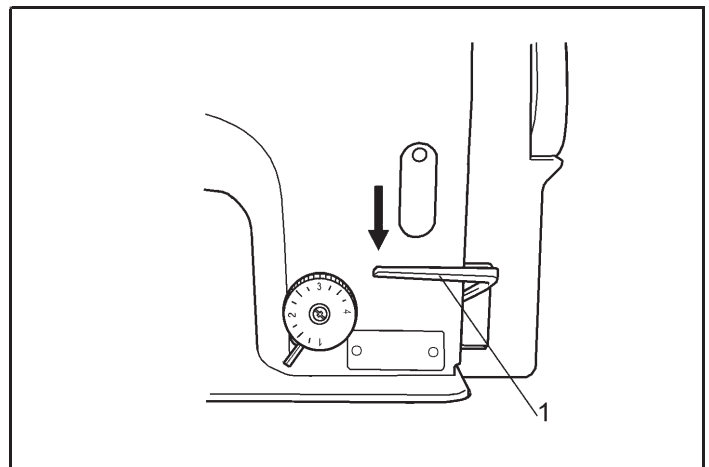

5-3. Sewing condensed stitches

● If you press the reverse lever (1) while sewing is in progress, you can sew stitches (forward direction) with small stitch lengths.

● Before carrying out sewing, set the stitch length for condensed stitches as follows.

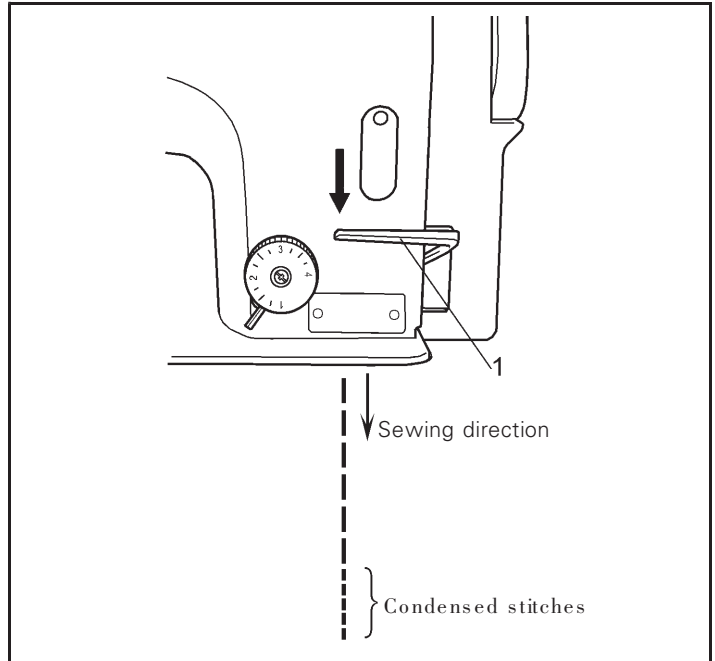

<Setting>

1. Unlock the stitch length dial (3) by turning the dial lock lever (2) to the right.
2. Turn the stitch length dial (3) to the stitch length to be used for condensed stitches.
3. Loosen the screw (4) and lift up the stopper (5) until it touches the reverse stitching lever plate (6).
4. Tighten the screw (4) to secure the stopper (5).

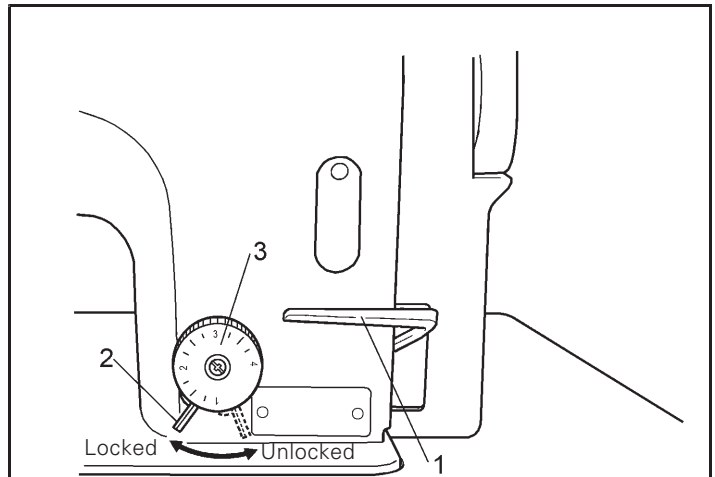

<Sewing>

1. Return the stitch length dial (3) to the stitch length for normal sewing.
 2. Turn the dial lock lever (2) firmly to the left to lock the stitch length dial (3).
 3. Start sewing.
 4. At the position where you would like to start sewing condensed stitches, press the reverse lever (1) (Condensed stitches are sewn while the reverse lever (1) is being pressed.)
- * To stop sewing condensed stitches and return to using the backtack function, lower the stopper (5) so that it does not touch the reverse stitching lever plate (6).

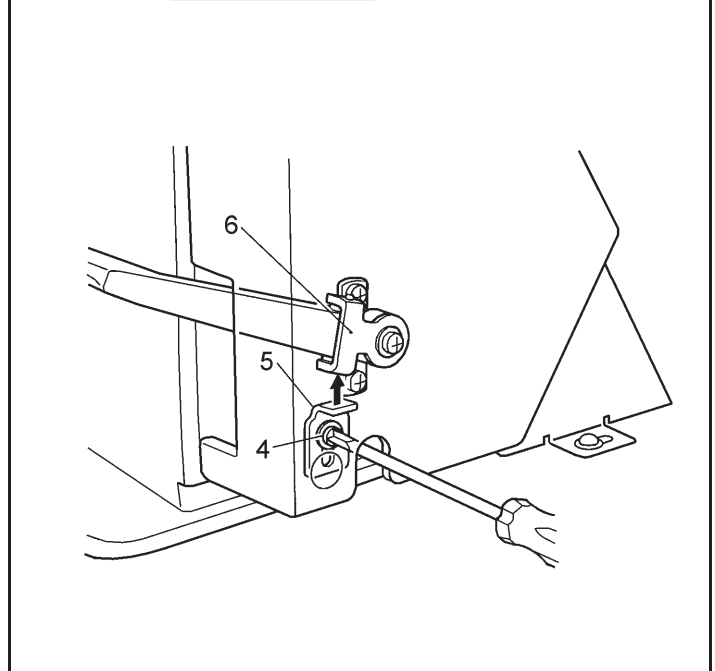

6. STANDARD ADJUSTMENT

6-1. Adjusting the thread tension



CAUTION



Turn off the power switch before adjusting the lower thread tension. The motor will keep turning even after the power is switched off as a result of the motor's inertia. Wait until the motor stops fully before starting work. The machine may operate if the treadle is depressed by mistake, which could result in injury.

Good even stitches.



Increase the upper thread tension.
Decrease the lower thread tension.



Decrease the upper thread tension.
Increase the lower thread tension.

<Lower thread tension>

Turn the adjusting screw (1) to adjust.

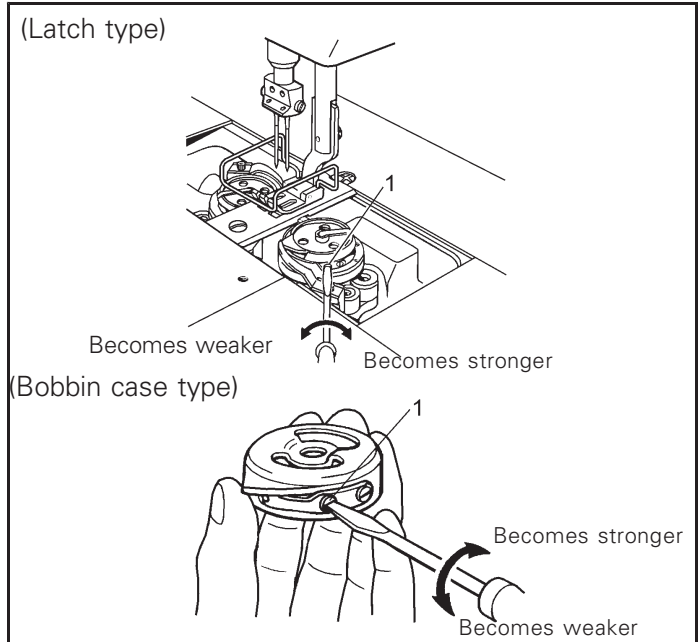

< Upper thread tension >

After the lower thread tension has been adjusted, adjust the upper thread tension so that a good, even stitch is obtained.

1. Lower the presser foot,
2. Adjust by turning the tension nut (2).

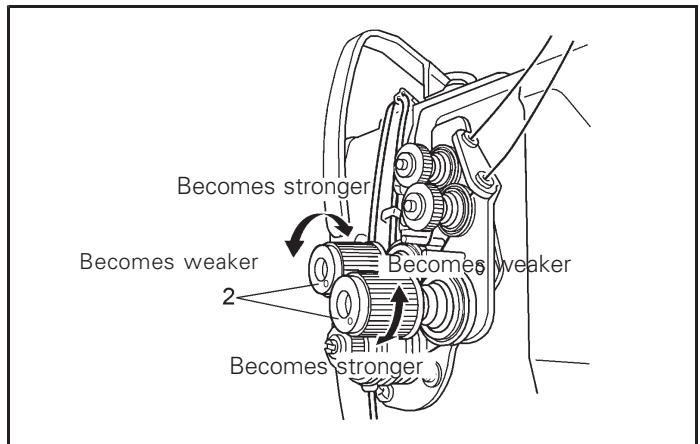

6-2. Adjusting the presser foot pressure

Correct stitches

 Upper thread

 Skipped stitches occur
Uneven stitch length

→ Increase the pressure

 Stitches are puckered

→ Decrease the pressure

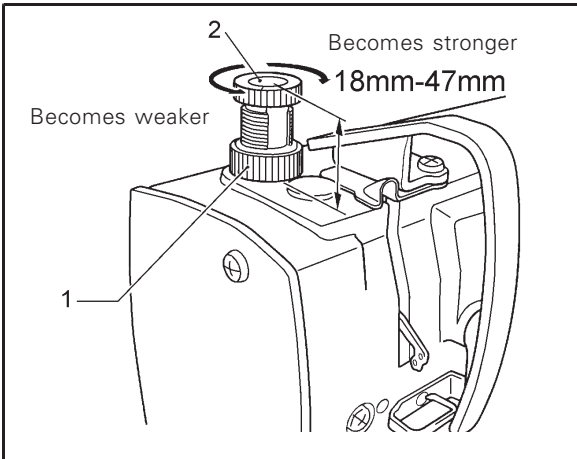

The presser foot pressure should be as weak as possible, but strong enough so that the material does not slip.

(Refer to "adjusting screw height" in the table below as a guide to adjustment.)

1. Loosen the adjusting nut (1).
2. Turn the presser adjusting screw (2) to adjust the presser foot pressure.
3. Tighten the adjusting nut (1).

Reference values

Use	Adjusting screw height
For light-weight and medium weight materials	Approx. 34mm
For heavy-weight materials	Approx. 29mm

6-3. Adjusting the thread take-up amount

the thread take-up amount is adjusted by how the thread is passed through the thread amount adjuster (1).

<Using the standard thread amount adjuster (1)>

For non-foundation specifications

Do not pass the thread through the thread amount adjuster (1). Loosen the screw (2) and slide the thread amount adjuster (1) to the right-side position.

For foundation specifications

Pass the thread through the thread amount adjuster (1). The standard position of the thread amount adjuster (1) is when the screw (2) is in the center of the adjustment range.

<Adjusting the thread take-up amount>

When the thread has been passed through the thread amount adjuster (1), the thread take-up amount becomes less when the thread amount adjuster (1) is moved to the right.

It is better not to pass the thread through the thread amount adjuster (1):

- When sewing heavy materials using a sewing machine with foundation specifications

- When the thread take-up amount is not enough, such as when the stitch length is increased.

It is better to pass the thread through the thread amount adjuster (1):

- When sewing with slippery threads such as synthetic yarns

- When sewing light materials

- When sewing with a stitch length of 2 mm or less

- When sewing under any of the above three conditions and you would like to prevent skipped stitches, thread tightening problems such as looping, or thread breakages

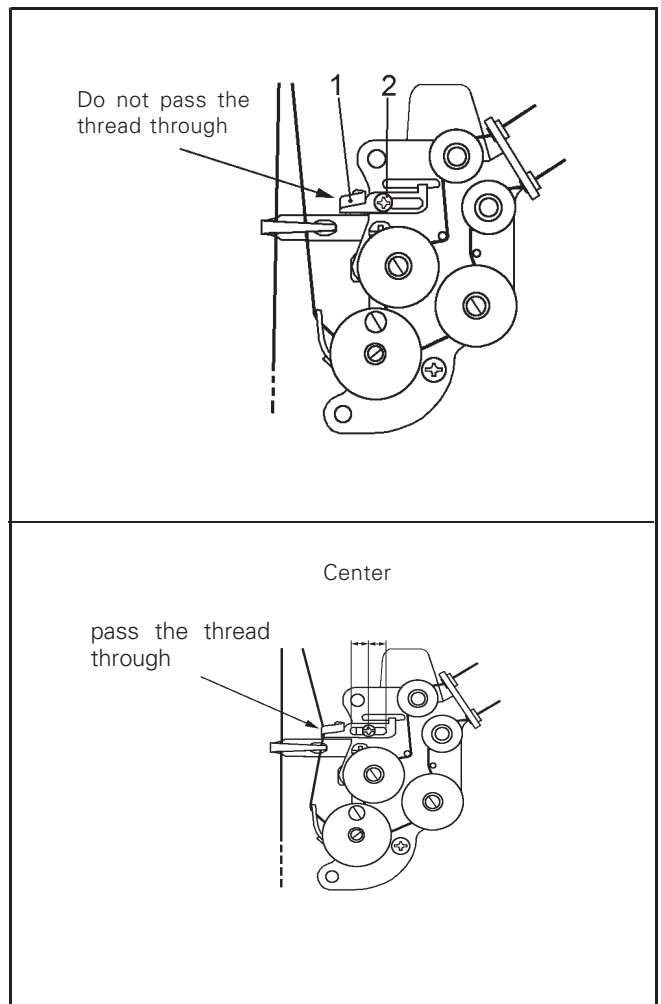

6-4.Adjustment of thread take-up spring

■ Intensity of thread take-up spring

The standard intensity of thread take-up spring R(1) and L(2) are as follows according to the specification of machines:

M	intensity 0.35N
H	intensity 0.70N

Thread takeup spring R(1) (For right thread)

1. Loosen the screw (3), turn the knob (4) to make adjustment.
2. Tighten screw (3).

Thread take-up spring L(2) (For left thread)

1. Loosen nut (5).
2. Turn the spool (6) with screwdriver (small) to make adjustment.
3. Tighten nut (5).

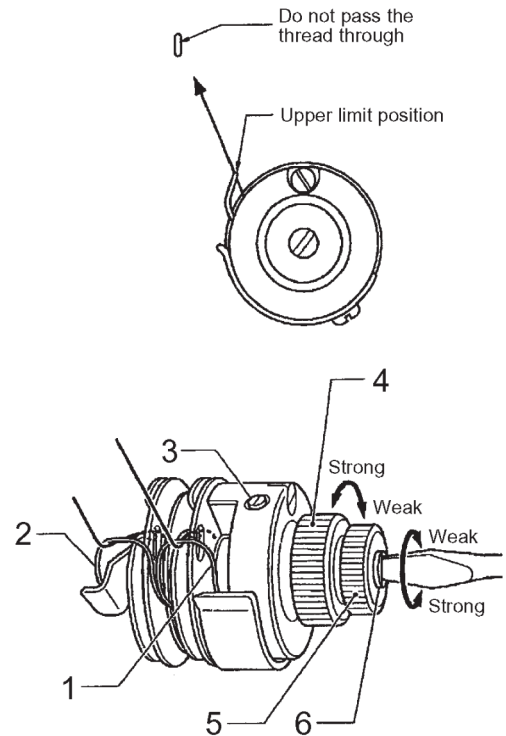

■ The thread take-up length of thread take-up spring

The standard thread take-up length for R(1) and L(2) is 7mm.

Change the height thread take-up spring stopper right (3) and left (4) to adjust the thread take-up length.

The height of thread take-up spring stopper right (3) (for right thread)

1. Loosen screw (6), slide thread take-up spring stopper right (3) to change the height;
2. Tighten screw (6)

The height of thread take-up spring stopper left (4) (for left thread)

1. Loosen screw (7), slide thread take-up spring stopper left (4) to change the height;
2. Tighten screw (7).

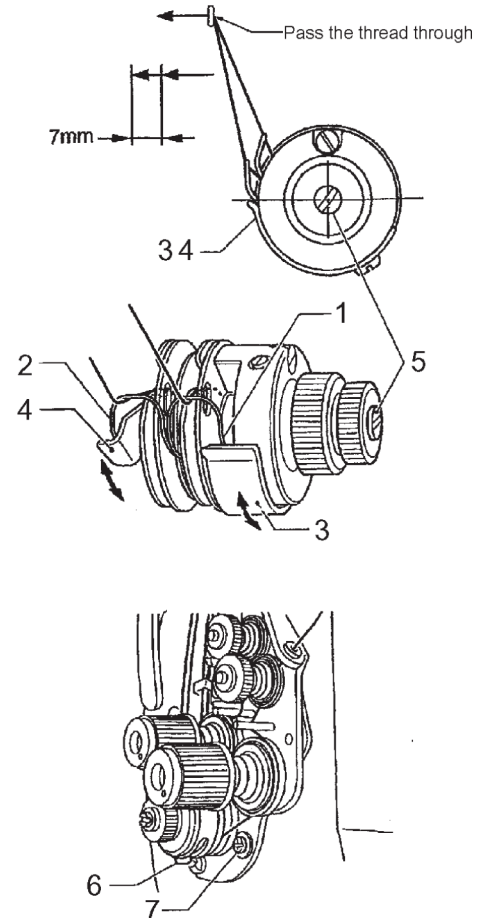

6-5. The synchronization of arm shaft and main shaft

<Normal machines>

1. Remove the needles.
2. Drop down the machine head.
3. Remove the timing belt (1).
Turn the hand wheel forward, and move the timing belt (1) to the right at the same time.
4. When the thread take-up lever at the upper position, hang the timing belt (1) on synchronous wheel D(2), and make the mark (3) on synchronous wheel D(2) and mark (4) on backplane coincide;
5. Hang the timing belt (1), and turn the hand wheel, move timing belt (1) to the left at the same time.

<The method of recognizing>

1. When the thread take-up lever at the upper position, the mark (3) on synchronous wheel D(2) and mark (4) on backplane should be coincide.
At the same time, through the middle of the window of belt cover, possible to see the mark (A) on hand wheel.
2. When the needle bar at the upper position, through the middle of the window of belt cover, possible to see the mark (—) on hand wheel.
3. Install the needles.

Machines with thread trimmer

1. Remove the needles.
2. Drop down the machine head.
3. Remove ring (4), remove connecting pin (5) and washer (6).
4. Remove screw (7), loosen screw (8).
5. Remove magnet (10).
6. Remove timing belt (11).
Turn the hand wheel forward, and move the timing belt (1) to the right at the same time.
7. When the thread take-up lever at the upper position, hang the timing belt (11) on synchronous wheel D(12), and make the mark (13) on synchronous wheel D(12) and mark (14) on backplane coincide.
8. Hang the timing belt (11), and turn the hand wheel, move timing belt (11) to the left at the same time.

<The method of recognizing>

1. When the thread take-up lever at the upper position, the mark (13) on synchronous wheel D(12) and mark (14) on backplane should be coincide.
At the same time, the mark on motor cover and the mark (A) on hand wheel should be coincide.
2. When the needle bar at the upper position, the mark on motor cover and the mark (—) on hand wheel should be coincide.
3. Install magnet (10).
4. Install the needles.

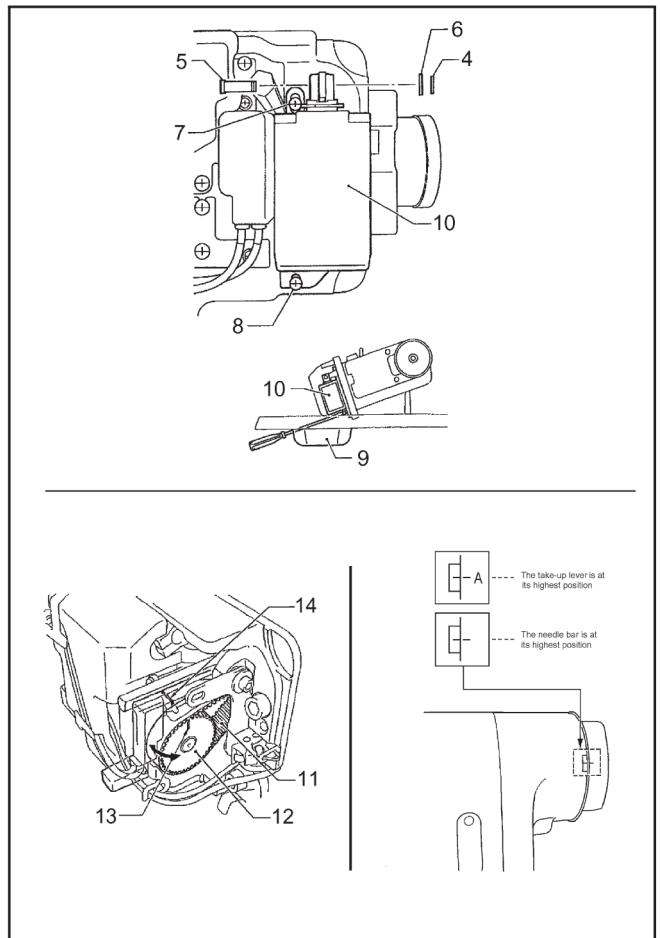
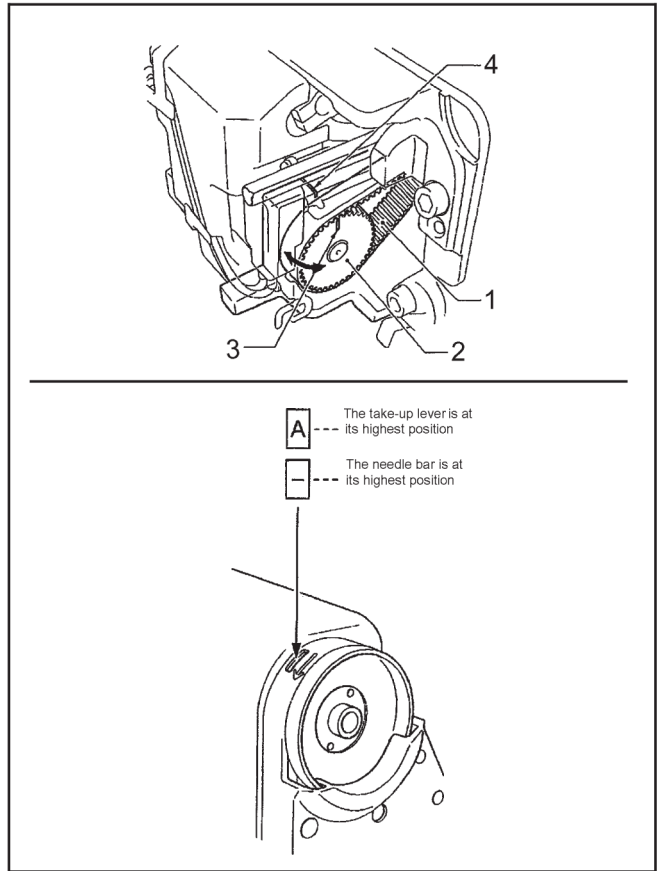

6-6. The synchronization of needle and hook

(GC9420/9720) Single needle bar

1. Make the feeding dial and real stitch length coincide.

Standard stitch length:

Specification	Feeding dial
M	2
H	3

2. Remove rubber plug (1).
3. When the needle bar (2) at the lower position, loosen the screw (5) and adjust the needle bar up and down to make the mark (3) on the top of needle bar (2) and the lower end of needle bar holder (4) coincide, please don't turn bar at this time.
4. Tighten the screw (5).
5. The space (A) and (B) between needle (6) and feed dog (7) should be similar.
6. Turn the hand wheel towards the operator, and make the needle bar (2) rise, till the baseline of needle bar (2) (according to the feeding situation (8) or (9)) and the lower end of needle bar holder (4) coincide.
7. In such a state, fix the hand wheel with sling and keep the needle bar (2) does not move.
8. Loosen the screw (10), remove the hook base cover FL(11) and FR(12).
9. Loosen the screw (13) (3pcs at both left and right side).
10. Turn the hook by hand, make the tip (15) of hook align to the center of needle.
11. Tighten the screw (13).
12. When the tip (15) of hook align to the center of needle, the distance between needle hole upper side and tip (15) should be 1-1.5mm.
13. Remove the sling which fixed the hand wheel.

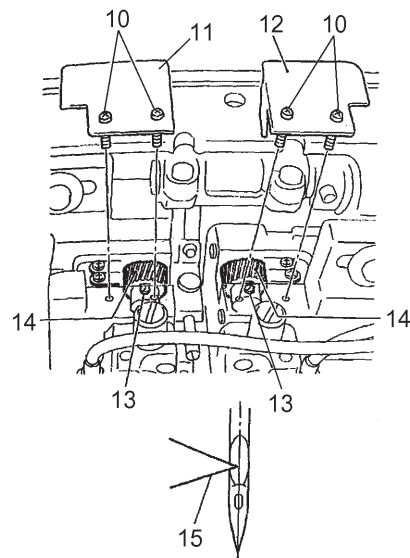
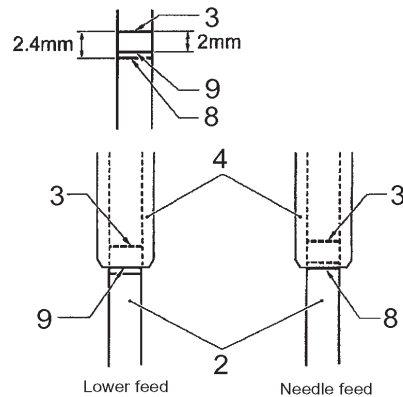
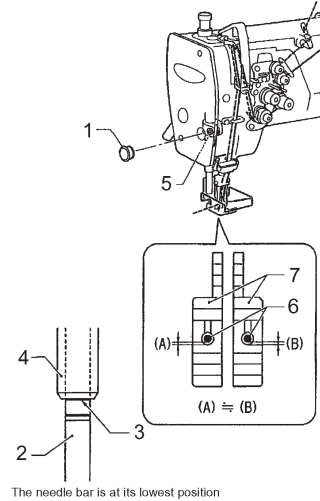

(GC9450/9750) Double needle bar

1. Set the stitch length dial to the actual length of the stitches to be sewn.

Standard stitch length

Specifications	Stitch length dial
M	2
H	3

2. Turn the machine pulley to raise the needle bar (1) by H mm from its lowest position. The reference line (A) on the needle bar (1) will be aligned with the lower edge of the needle bar base (2). The rotary hook tip (3) must be aligned with the center of the needle at this time.

Needle bar height (H)	Needle feed	2.4 mm
	Lower feed	2 mm

3. Loosen the screws (4), and then remove rotary hook base cover FL (5) and FR (6).
4. Loosen the set screws (7) (three each at left and right).
5. Turn the rotary hook by hand to align the rotary hook tip (3) with the middle of the needle.
6. Tighten the set screws (7).
7. With the needle raised, turn the machine pulley forward while pushing the needle against the rotary hook tip (3) with your finger to make a mark from the rotary hook tip (3) in the hollow of the needle.
8. Check that the distance (C) from the intersection between the mark from the rotary hook tip (3) and the center line of the needle to the top edge of the needle hole is 1–1.5mm.

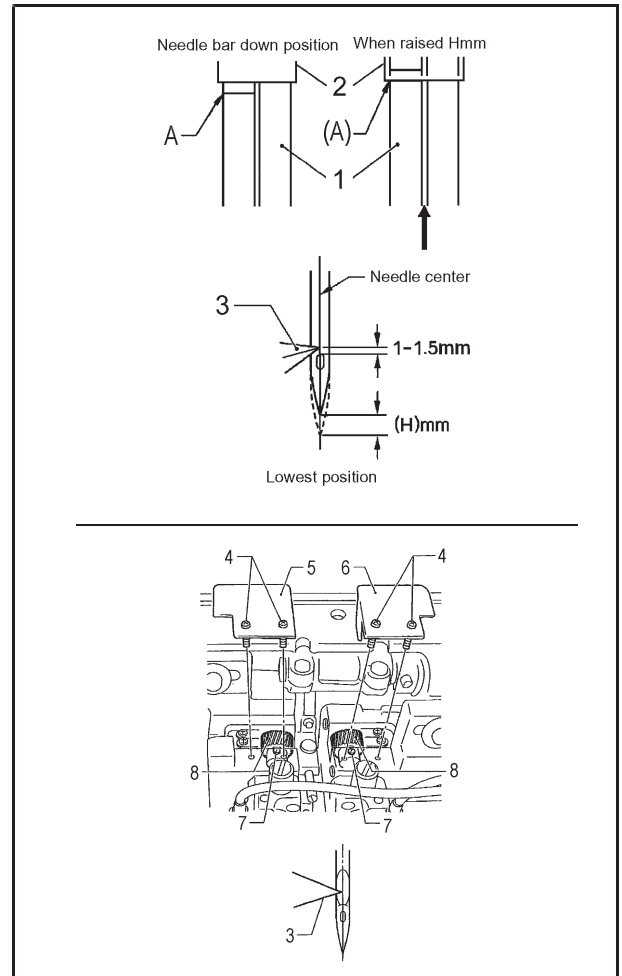

6–7. The gap between needle and hook tip

When change the needle gauge or adjust the space between needle and hook tip, move the hook holder to the left or right to make adjustment.

1. Drop down the machine head.
2. Loosen the screw (1) (4pcs).
3. Loosen the screw (2) (2pcs) a little, make the hook base (7) movable.
4. Loosen the screw (3) (2pcs).
5. Loosen the screw (4) (3pcs at both left and right side).
6. Loosen the bolt (8) (2pcs) on machine with thread trimmer.
7. Move the hook holder (7) to the left or right, and tighten with the screw (1) at the approximate position (hook tip (9) to the final position is about 0.2mm, far position from the needle). At this time, move the eccentric direction of gap adjustment shaft (5) (2pcs) same as the illustration.
8. Turn the gap adjustment shaft (5), move the hook holder (7) to the left or right slightly, make the space between needle and hoop tip (A) not less than 0.05mm, at this time, make the space between needle and needle holder (10) less than the space between needle and hook tip (A).
9. Tighten the screw (2) and (3).
Tighten the screw (4) (3pcs at both left and right side).
10. For machine with thread trimmer
Tighten the bolt (8)

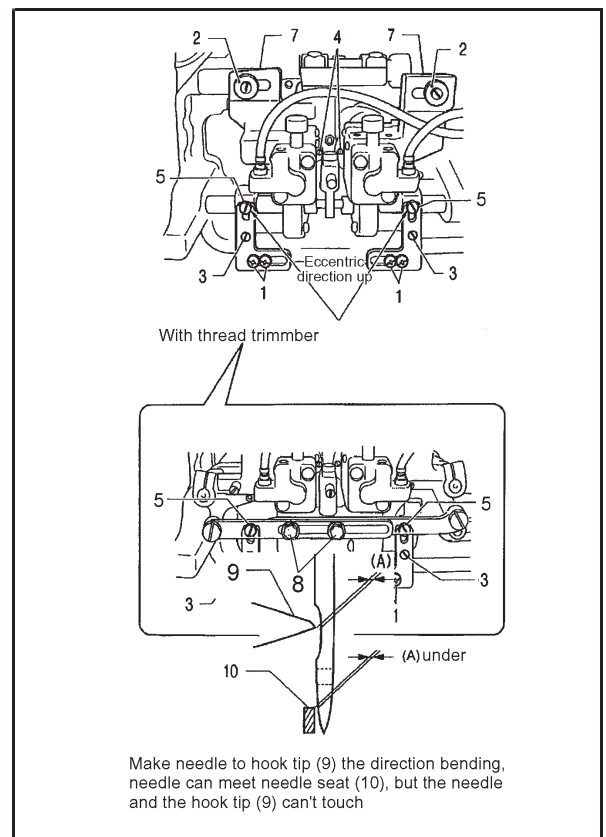

6-8. CLEARANCES BETWEEN ROTARY HOOKS AND NEEDLE PLATE

The clearance between the rotary hooks

(1) and the needle plate

(2) have been adjusted to about 1.4–1.7 mm with a spacer. Loosen the screws

(3) and exercise care not to lose the spacer when replacing the rotary hooks.

* If two spacers are used, be sure to use both of them under the rotary hooks.

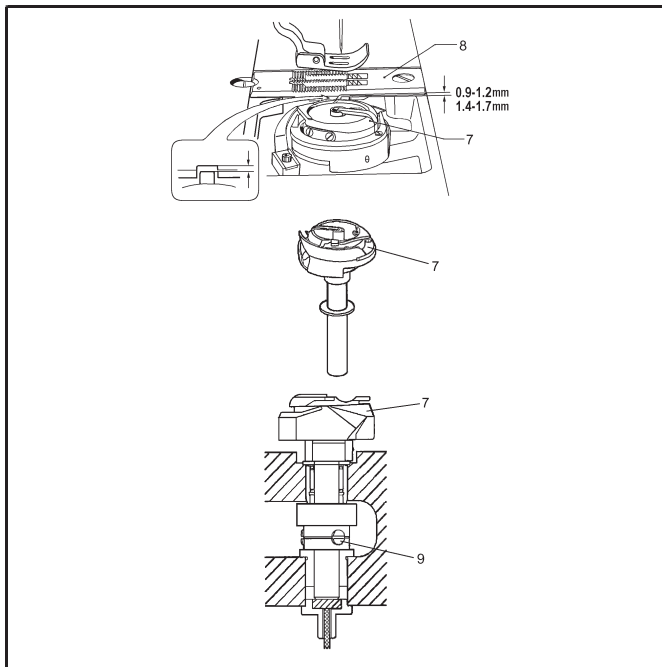

6-9. CLEARANCES BETWEEN ROTARY HOOKS AND OPENER

1. Loosen the set screw (11) and move the opener (10) to the left or right to adjust so that the clearance between the rotary hook (7) and the opener (10) is 0.2 mm when the opener (10) is pulled as far as it will go in the direction of the arrow.

2. Tighten the set screw (11).

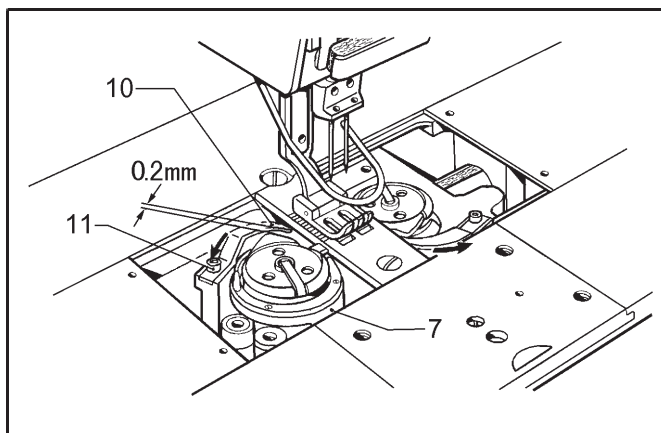

6-10. THREAD WIPER ADJUSTMENT (For D3 series)

1. Stop the machine while the needle bar is at its highest position.

2. Turn off the power switch.

3. Set the stitch length to "2" on the scale.

■ Adjusting the forward and back position

4. Loosen the screws (2) and move the solenoid (3) up and down to adjust so that the tips of the thread wiper (1) are 0.3–0.5 mm forward of the tips of the needles when the thread wiper (1) is pressed by hand as shown in the illustration.

5. Securely tighten the screws (2).

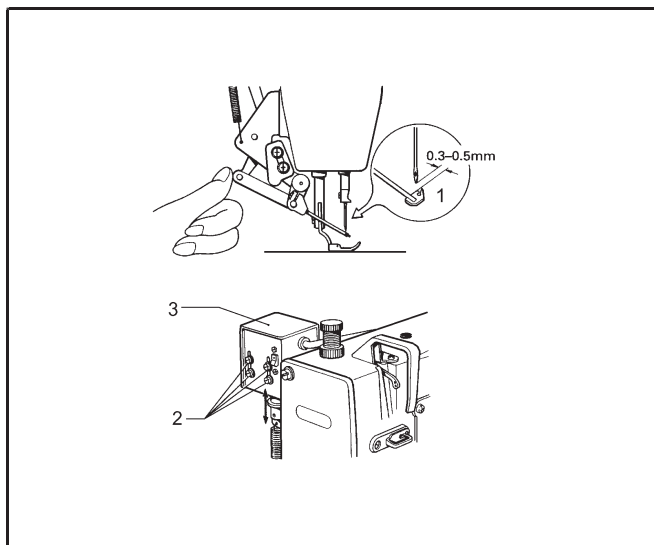

■ Adjusting the left and right position

6. Loosen the screws (4) and move the thread wiper (1) to the left and right to adjust so that the tips of the thread wiper (1) are 0.3–0.5 mm to the inside of the needle center lines,
7. Securely tighten the screws (4).

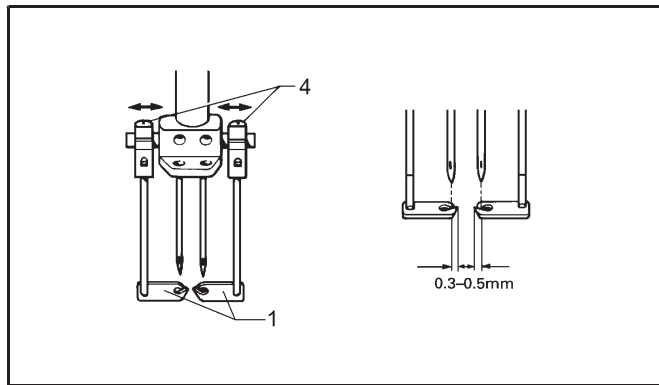

■ Adjusting the return position

8. Loosen the screws (6) , and raise or lower the stopper (7) until the clearance between the tip of thread wiper (1) and the presser bar (5) is about 3 mm when the thread wiper (1) returns to its original position.
 9. Securely tighten the screws (6).
- * If the clearance is too little, the thread wiper (1) may not be able to hook the threads depending on the kind of thread. Set the thread wiper (1) as close to the needle as possible, provided that the threads will positively pass through the work. Also check that the needle set screws will not contact the thread wiper.

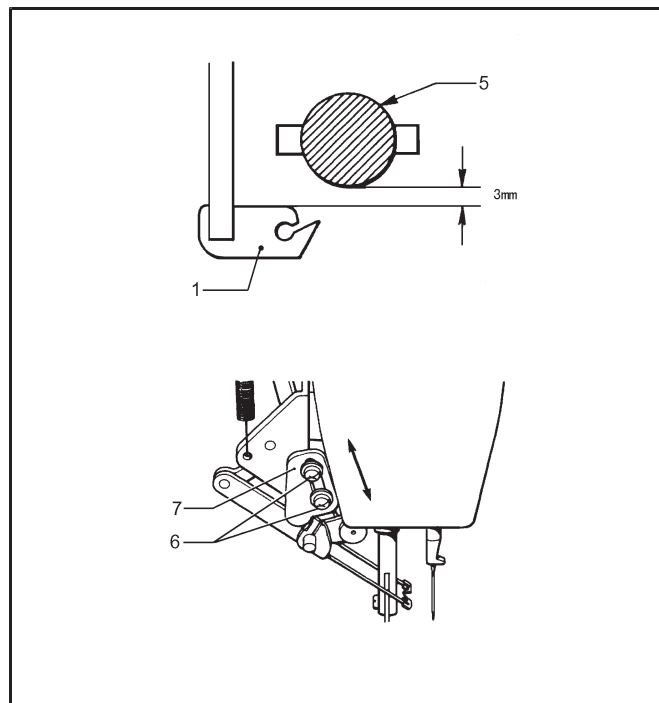

■ Adjusting the vertical position

The tip of the thread wiper (1) will travel as indicated by the dotted lines.

10. Loosen the screw (4) and turn the thread wiper supporter (5) to adjust so that the clearance between the tip of the needle and the thread wiper (1) is 0.5–1 mm when the thread wiper (1) is pressed by hand as shown in the illustration.
 11. Securely tighten the screw (4).
- After adjustment, carry out a test sewing to check that the thread wiper operates correctly.

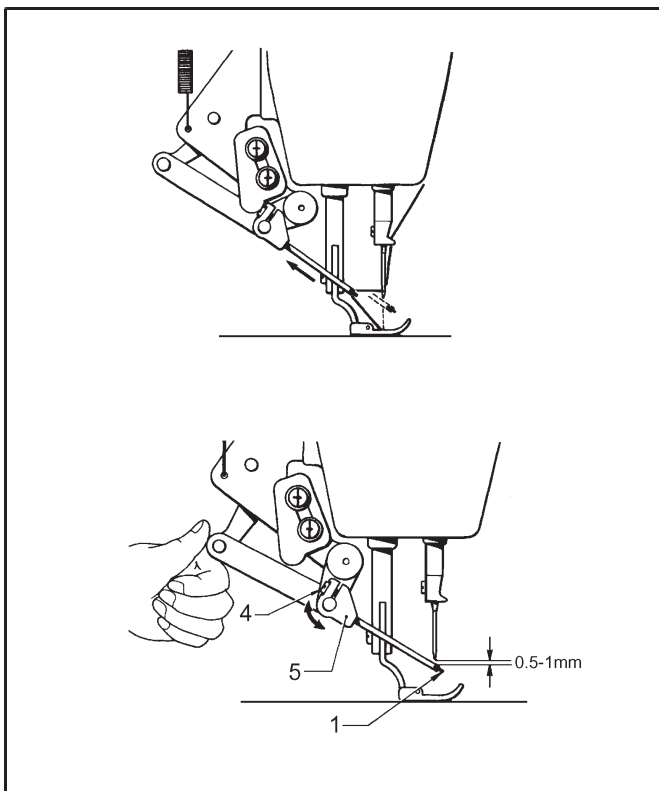

6-11. MOVABLE AND FIXED KNIFE ADJUSTMENT (For D3 series)

■ Removing the movable and fixed knives

1. Remove the needles and raise the presser foot.
2. Loosen the screws (1) and (2), and then remove the needle plate (3).
3. Remove the holed screws (4) and remove the movable knife (5).

- * Be careful not to scratch the tip of the movable knife (5).
- 4. Remove the screws (6) and remove the fixed knife (7).

■ Sharpening the fixed knife

If the knives become blunt, sharpen the fixed knives (7) as shown.

The moving knife (5) cannot be sharpened with an ordinary whetstone.

If it becomes blunt, replace it with a new one.

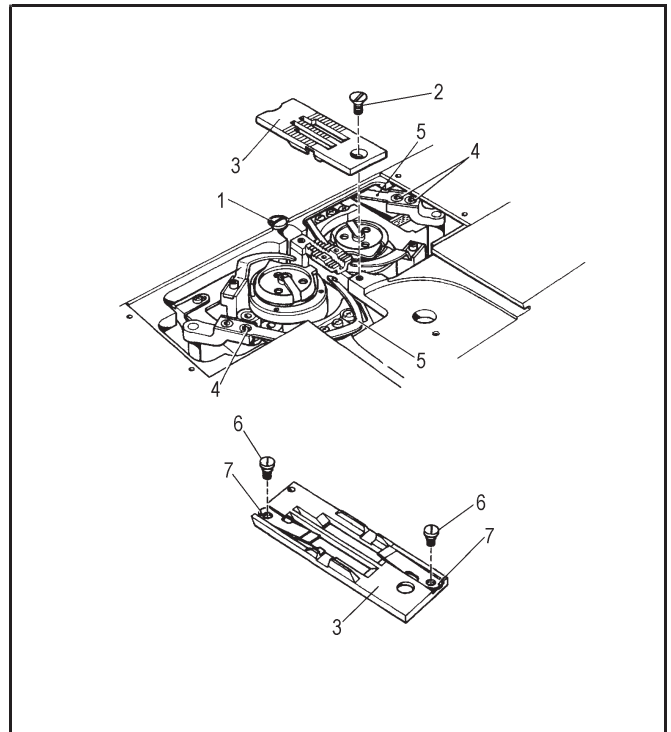
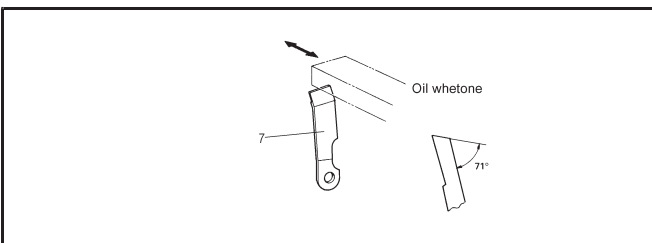

■ Installing the movable and fixed knives.

1. Turn the machine pulley by hand until the openers (9) are pulled all the way in the arrow direction.
2. Lightly secure the movable knife (5) with screws (4).
- * Install the movable knife (5) on the top of the bobbin thread clamp spring (10).
3. Press down on the top of the movable knife (5) and slide the movable knife. (Firmly tighten screw (4) so that the gap between the tip of the movable knife and rotary hook position bracket is 0.05 to 0.2 mm.
4. Tilt back the machine head.
5. Loosen the screws (11).
6. Move the movable knives (5) with your finger so that they are at the positions shown in the illustration.
7. Tighten the screws (11).
8. Fasten the fixed knife (7) to the needle plate with the screws (6).
9. Fasten the needle plate with the screws (1) and (2).
10. Install the needles in the needle clamp and lower the presser foot.

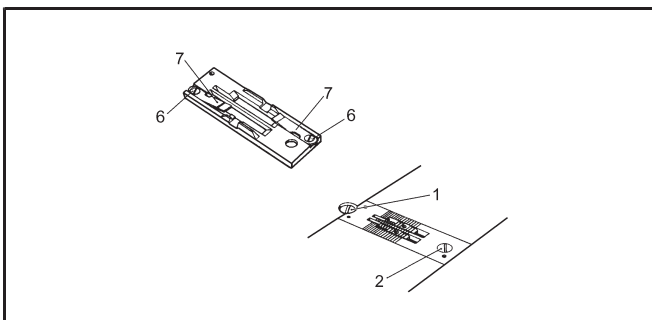
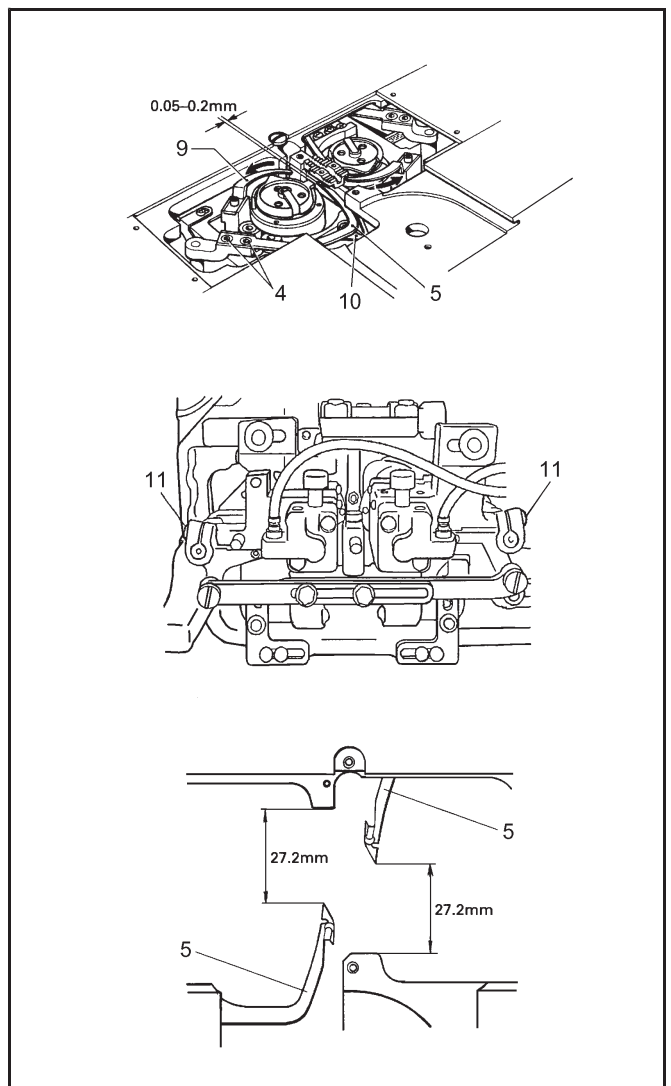

6-12. TENSION RELEASE (For D3 series)

If the thread slips out of the needle hole after thread cutting, or if the tension disc remains open, adjust as follows.

A.If the thread slips out of the needle hole (The tension release is not working properly during thread cutting.)

1. Press the thread trimming solenoid (1) and turn the sewing machine pulley.
2. The tension disc (4) should be open 0.8 mm when the tension release lever (2) roller reaches the top of the tension release cam (3).If the tension disc (4) is not open, turn nut (5) to adjust.
3. Make sure the tension disc (4) is open when the tension release lever (2) roller is at the top of the tension release cam (3), and closed when the lever roller is on the level.

B.If the tension disc remains open

1. Make sure the tension release lever (2) is returned.
2. Make sure the return spring (6) is not disengaged. Check the above and adjust with nut (5) as necessary. If adjustment is not possible, replace the tension release wire (7).

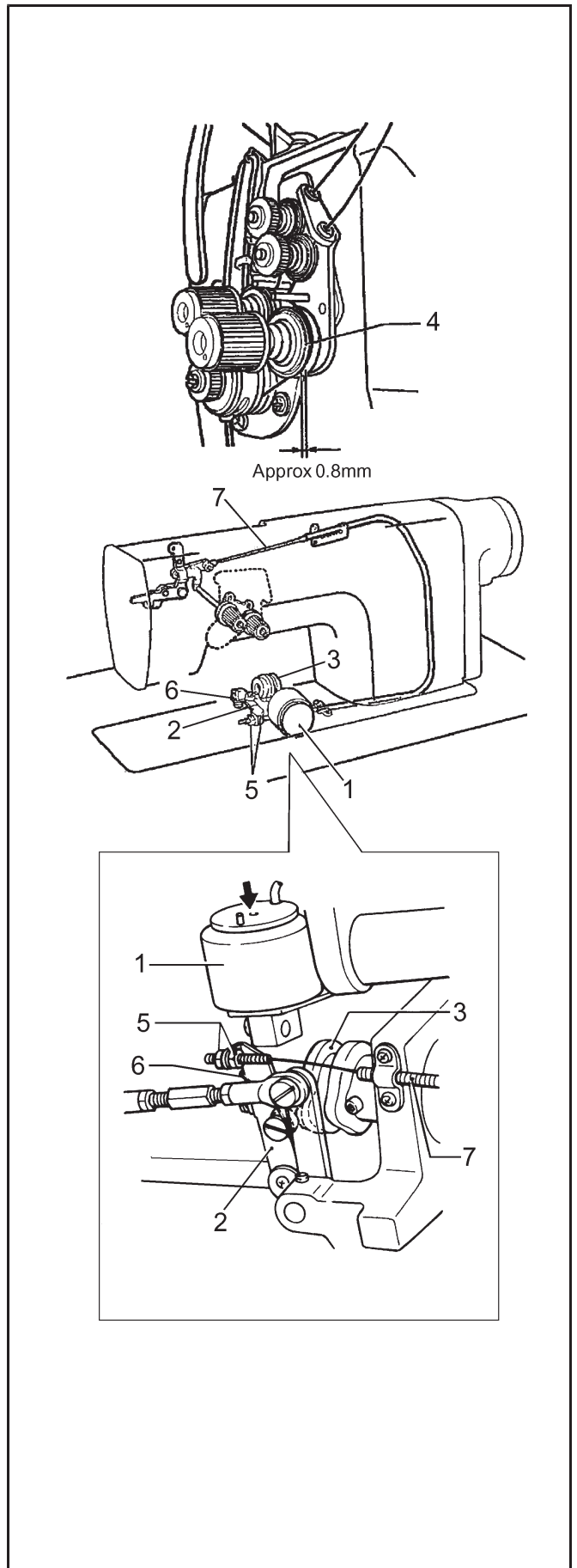

6-13. ADJUSTING THE ROTARY HOOK LUBRICATION AMOUNT



CAUTION



Be careful not to touch your fingers or the lubrication amount check sheet against moving parts such as the rotary hook or the feed mechanism when checking the amount of oil supplied to the rotary hook, otherwise injury may result.

Use the following procedure to check the amount of oil being supplied to the rotary hook when replacing the rotary hook or when changing the sewing speed.

<Guide to lubrication adjustment>

1. Tilt back the machine head.
2. Turn the oil adjusting screw (1) to adjust the height to within 9–14 mm.

<Checking the lubrication amount>

1. Turn off the power switch.
2. Remove the thread from all points from the thread take-up to the needle.
3. Remove the needle and the bobbin.
4. Use the lifting lever to lift the presser foot.
5. Turn on the power switch.
6. Run the machine at the normal sewing speed for approximately 1 minute without sewing any material (following the same start/stop pattern as when actually sewing).
7. Place the lubrication amount check sheet (2) to the left of the rotary hook (the right side is the right side of the rotary hook), and hold it in place while running the sewing machine at the normal sewing speed for approximately 8 seconds. (Any type of paper can be used as the lubrication amount check sheet (2).)
8. Check the amount of oil which has spattered onto the sheet.

<Adjusting the lubrication amount>

1. Tilt back the machine head.
2. Turn the adjusting screw (1) to adjust the lubrication amount.
 - If the rotary hook adjusting screw (1) is turned counter-clockwise, the lubrication amount becomes greater.
 - If the rotary hook adjusting screw (1) is turned clockwise, the lubrication amount becomes smaller.
3. Check the lubrication amount again according to the procedure given in "Checking the lubrication amount" above.
 - * Turn the adjusting screw (1) and check the lubrication amount repeatedly until the lubrication amount is correct.
4. Check the lubrication amount again after the sewing machine has been used for approximately two hours.

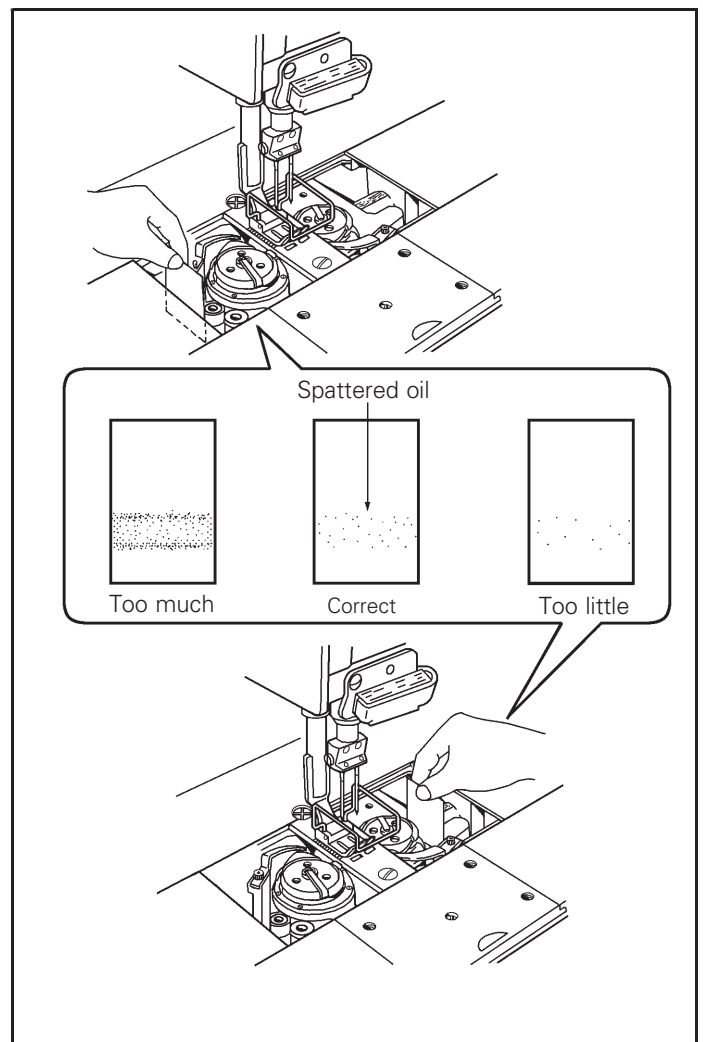
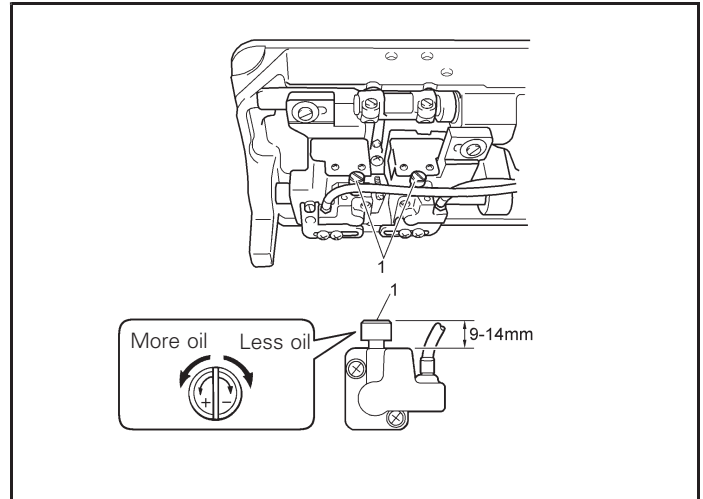

7. CLEANING



CAUTION



Turn off the power switch before carrying out cleaning. The motor will keep turning even after the power is switched off as a result of the motor's inertia. Wait until the motor stops fully before starting work. The machine may operate if the treadle is depressed by mistake, which could result in injury.



Be sure to wear protective goggles and gloves when handling the lubricating oil and grease, so that they do not get into your eyes or onto your skin, otherwise inflammation can result. Furthermore, do not drink the oil or eat the grease under any circumstances, as they can cause vomiting and diarrhea. Keep the oil out of the reach of children.



Use both hands to hold the machine head when tilting it back or returning it to its original position. If only one hand is used, the weight of the machine head may cause your hand to slip, and your hand may get caught.

7-1. Daily cleaning procedures

The following cleaning operations should be carried out each day in order to maintain the performance of this machine and to ensure a long service life.

Furthermore, if the sewing machine has not been used for a long period of time, carry out the following cleaning procedures before using it again.

<Cleaning>

1. Turn the machine pulley to move the needle to the needle up stop position.
2. Open the slide plates at the left and right.
3. Remove the bobbin.
4. Clean the thread scraps from the rotary hook.
5. Install the bobbin (and the bobbin case).

<Filling the oil tank>

Use only the lubricating oil specified by our company.

1. If the lubricating oil level drops below the bottom reference line (2) of the oil gauge window (1), be sure to add more oil.

<Checking>

1. Replace the needle if it is bent or if the tip is broken.
2. Check that the upper threads have been threaded correctly.
3. Carry out a test sewing.

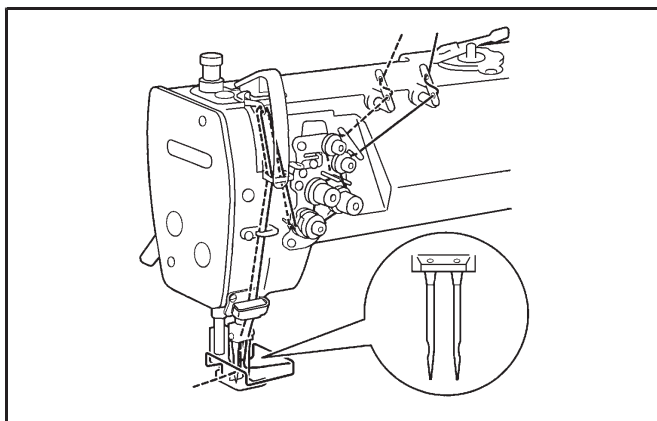
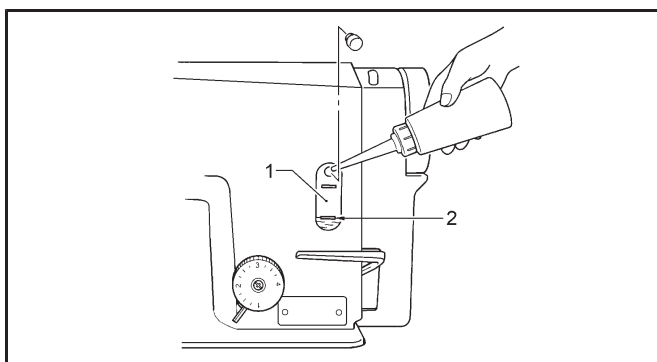
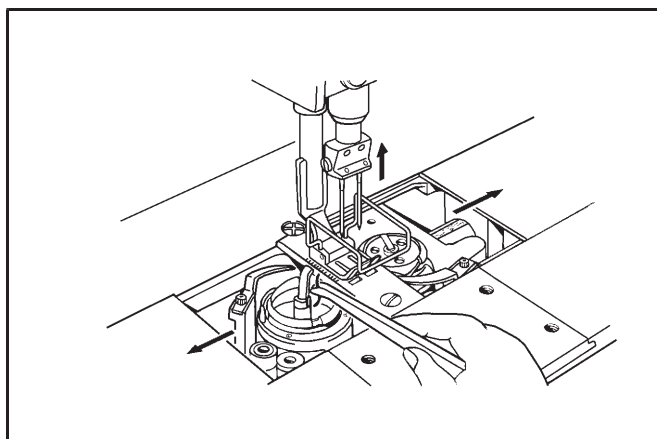

<Draining lubricating oil>

1. If the oiler (1) has filled with oil, unscrew the oiler (1) and dispose of the oil inside it.
2. Screw the oiler (1) back into the oil pan.

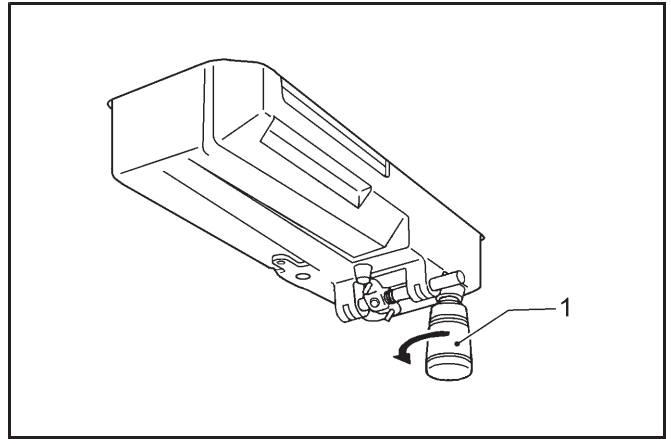

7-2. Lubricating via the oil cover (every 6 months)

<Minimum lubrication type>

Pour lubricating oil into the oil cover (1) about once every six months.

<Semi dry type>

Pour lubricating oil into the oil cover (1) about as often as grease is applied.

Use only the lubricating oil specified by our company .

1. Tilt back the machine head.
2. Pour lubricating oil into the oil cover (1) until the oil level reaches the reference line (2).
3. Return the machine head to its normal position.

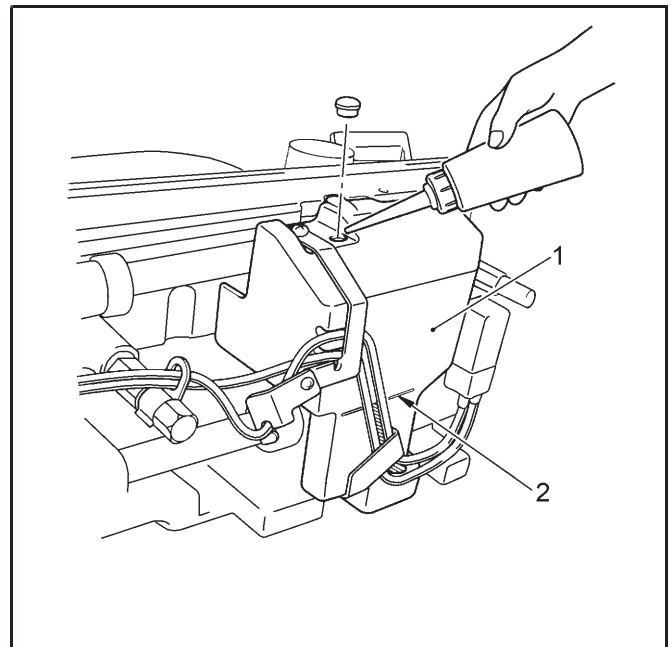

8. TROUBLESHOOTING





- Please check the following points before calling for repairs or service.
- If the following remedies do not fix the problem, turn off the power switch and consult a qualified technician or the place of purchase.

⚠ CANTION



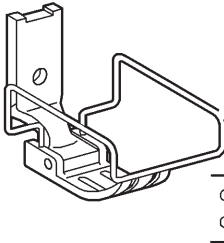

Turn off the power switch and disconnect the power cord before carrying out troubleshooting. The motor will keep turning even after the power is switched off as a result of the motor's inertia. Wait until the motor stops fully before starting work.

The machine may operate if the treadle is depressed by mistake, which could result in injury.

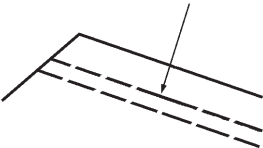
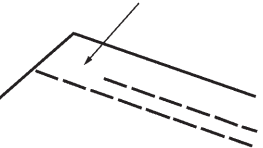
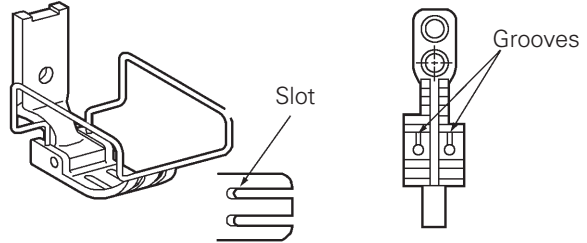
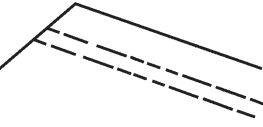
Problem	Possible cause
<p>1. Machine does not operate when power is turned on and treadle is pressed.</p>	<ul style="list-style-type: none"> ● Is a breaker or fuse blown? ● Is the power cord disconnected? ● Is the V-belt installed?
<p>2. Upper thread is not tight.</p>  <p>Lower thread is not tight.</p> 	<ul style="list-style-type: none"> ● Has the thread been threaded incorrectly? If the thread is threaded incorrectly, thread it correctly. ● Is the upper thread tension or lower thread tension too weak? Adjust the upper thread tension or lower thread tension. ● Is the thread take-up spring operating range too small? Lower the position of the stopper. <div style="border: 1px solid black; padding: 10px; margin-top: 20px;"> <p>If using a sewing machine with medium-weight material specifications, poor thread tightening may occur depending on the type of material being sewn. In such cases, replace the presser foot with one that has slots on the underside, or replace the feed dog with a grooved feed dog.</p> <div style="display: flex; justify-content: space-around; align-items: center;"> <div style="text-align: center;">  <p>Slot</p> </div> <div style="text-align: center;">  <p>Grooves</p> </div> </div> </div>
<p>3. Loops appear in seam.</p> 	<ul style="list-style-type: none"> ● Is the thread path not smooth enough? Use a file with a fine grain or sandpaper to polish smooth the thread path. ● Is the bobbin not turning smoothly? Pull out the lower thread to check that there is no slackness in the thread tension, or replace the bobbin or bobbin case. ● Is the thread take-up amount too large? Adjust the thread take-up amount.

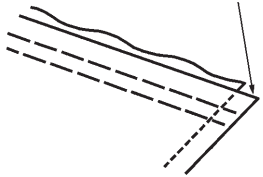
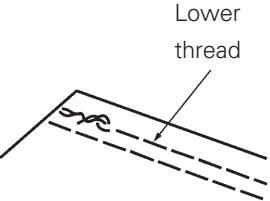
Problem	Possible cause
<p>4. Skipped stitches occur while sewing</p> 	<ul style="list-style-type: none"> ● Is the needle tip bent? Is the needle tip blunt? If the needle tip is bent or broken, replace the needle. ● Is the needle properly installed? If it is incorrect, install the needle correctly. ● Is the machine properly threaded? If it is incorrect, thread the thread correctly. ● Is the presser foot pressure too weak? Adjust the presser foot pressure. ● Is the needle too thin? Replace the needle with a needle that is one rank thicker. ● Is the presser foot too high? Adjust the height of the presser foot. ● Is the thread take-up spring too weak? Adjust the tension of the thread take-up spring. ● Is the thread take-up amount too large? Adjust the thread take-up amount.
<p>5. Skipped stitches at sewing start Thread unravelling at sewing start</p> 	<ul style="list-style-type: none"> ● Is the thread take-up spring tension too strong? Reduce the tension of the thread take-up spring. ● Is the thread take-up spring operating range too large? Raise the position of the stopper. ● Is the thread take-up at its highest position at the sewing start? Set the thread take-up to its highest position at the sewing start. ● Is the length of the upper thread trailing from the needle hole too short? Pull about 50 mm of thread through the needle hole at the sewing start. ● Is the needle too wide? Try using a needle with a count that is one lower than the current needle. ● If sewing light or medium-weight materials, is a presser foot with slots on the under-side or grooved feed dog being used? Use a presser foot without slots. Use a feed dog without grooves. <div style="text-align: center; margin-top: 20px;">  </div>
<p>6. Uneven seam</p> 	<ul style="list-style-type: none"> ● Is the presser foot pressure too weak? Adjust the presser foot pressure. ● Is the feed dog too low? Adjust the feed dog height. ● Is the bobbin scratched? If the bobbin is damaged, smooth it with an oiled grindstone or replace it. ● Is the V-belt tension too low? Adjust so that there is 10–14 mm of deflection in the V-belt when it is pushed with a finger.

Problem	Possible cause
<p>7. Large degree of puckering (excess tension)</p> 	<ul style="list-style-type: none"> ● Is the upper thread tension too strong? Make the upper thread tension as weak as possible. ● Is the lower thread tension too strong? Make the lower thread tension as weak as possible. ● Are the thread take-up spring tensions too strong? Make the thread take-up spring tension as weak as possible. ● Is the thread take-up spring operating range too large? Move the stopper to as high a position as possible. ● Is the presser foot pressure too strong? Adjust the presser foot pressure. ● Is the thread take-up amount too small? Adjust the thread take-up amount.
<p>8. Material slippage</p> 	<ul style="list-style-type: none"> ● Is the presser foot pressure too strong? Adjust the presser foot pressure.
<p>9. Lower thread is tangled at the sewing start.</p> 	<ul style="list-style-type: none"> ● Is the bobbin spinning direction correct when the lower thread is being pulled? Set the bobbin so that it turns in the opposite direction to the rotary hook. ● Is there too much thread wound onto the bobbin? The bobbin winding amount should not be more than 80% ● the bobbin turning smoothly? If the bobbin is not turning smoothly, replace the bobbin 

10 Upper and lower threads are breaking.

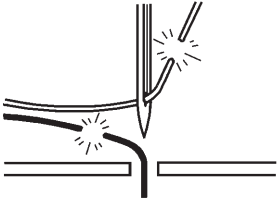

- Is the needle bent or is the needle tip broken?
Replace the needle if it is bent or broken.
- Is the needle properly installed?
If it is incorrect, install the needle correctly.
- Is the machine properly threaded?
If it is incorrect, thread the thread correctly.
- Is the oil tank filled with lubricating oil?
If the level of lubricating oil is below the bottom reference line, add more oil.
- Is the upper or lower thread tension too weak or too strong?
Adjust the upper thread or lower thread tension.
- Is the rotary hook blocked with dust or thread scraps?
Clean the rotary hook.
- Is the upper thread may be loose because the thread take-up spring operating range is too small?
Adjust the position of the stopper.
- Is the rotary hook, feed dog or other part damaged?
If they are damaged, smooth them with an oiled grindstone or replace the damaged parts.
- Is the thread path damaged?
If the thread path is damaged, smooth it with sandpaper or replace the damaged part.
- Is the thread take-up amount correct?
Adjust the thread take-up amount.

11. Broken needles

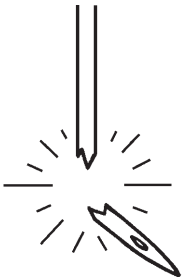

- Is the material being pushed or pulled with excessive force during sewing?
- Is the needle bent, is the needle tip broken, or is the needle hole blocked?
Replace the needle.
- Does the needle drop into the center of the needle hole in the feed dog?
Check the needle drop position. If the needle does not drop into the center of the needle hole in the feed dog, reinstall the feed dog.
If the needle bar has rotated, rotate the needle bar to the correct position.

Caution

- It is extremely dangerous to leave any pieces of broken needle sticking in the material. If the needle breaks, search for all pieces until the whole of the needle is found again.
- Furthermore, we recommend we recommend that through steps be taken to

1-1. MACHINE BODY(9420、9720)

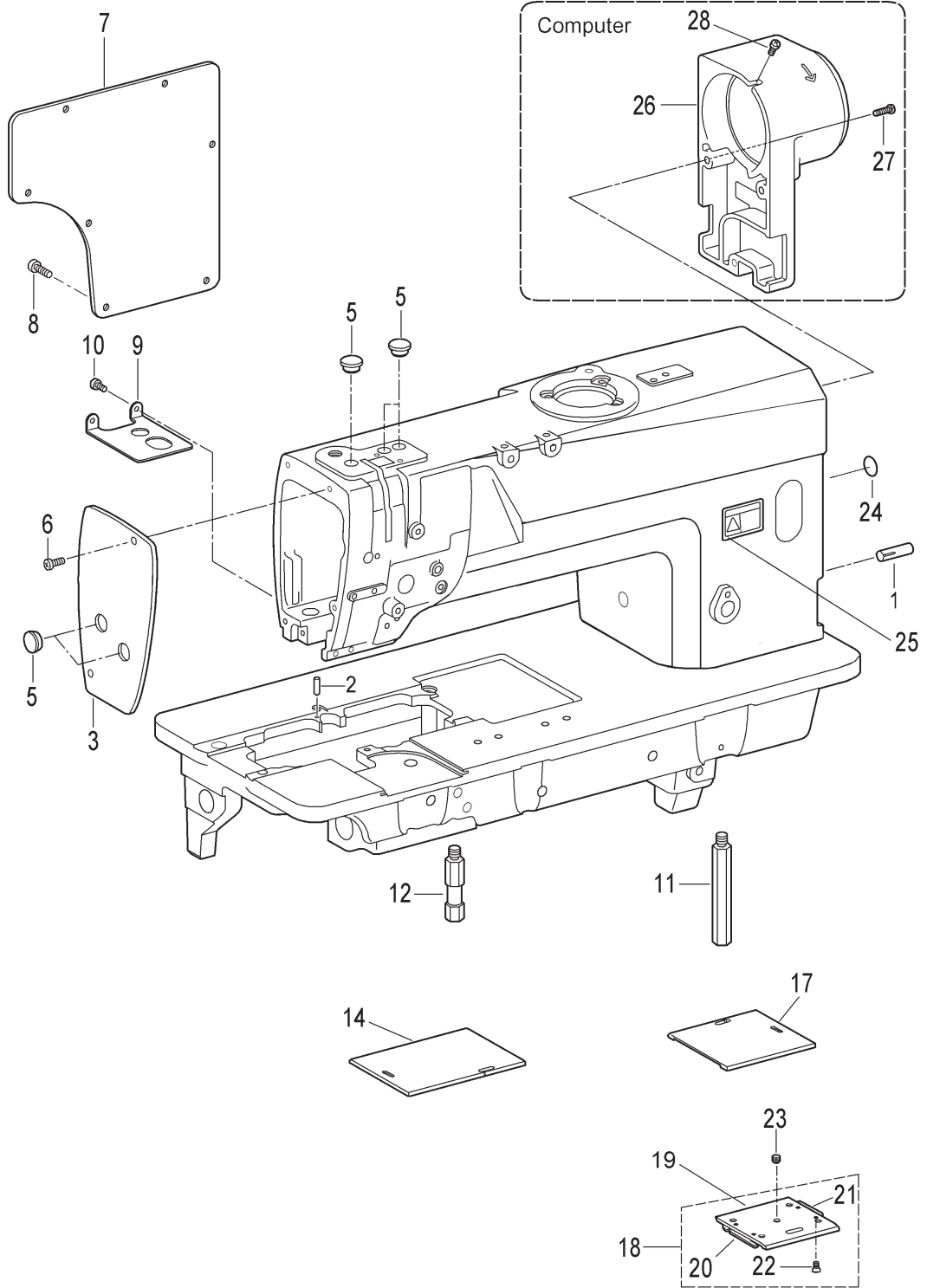

1-1. MACHINE BODY(9420、 9720)

No.	Ref.No	Description	Qt	Note
1	B960047009	Dowel pin	1	
2	BXF7186009	Positioning pin	1	
3	216000001	Face plate	1	
5	BXF8181009	Rubber plug 12.5	5	
6	B048500294	Screw M5X80	2	
7	216000002	Rear cover	1	
8	B048509894	Screw M5X12	7	
9	BXF8667009	Dust protector	1	
10	B048500494	Screw M5X6	2	
11	BXF8666009	Bed leg, L	1	
12	BXF8665009	Bed leg, S	1	
14	BXF8662009	Slide plate L	1	
17	BXF8650009	Slide plate R	1	
18	BX74447059	Slide plate assy, front	1	
24	036E02002	Label, grounding	1	
25	QT000015	Label, caution english	1	
26	BXF8668009	Motor cover	1	
27	B048509694	Screw M5X14	3	
28	B048509094	Screw M5X10	1	

* The part circled by □ is supplied in complete set.

1-2.MACHINE BODY (9450、9750)

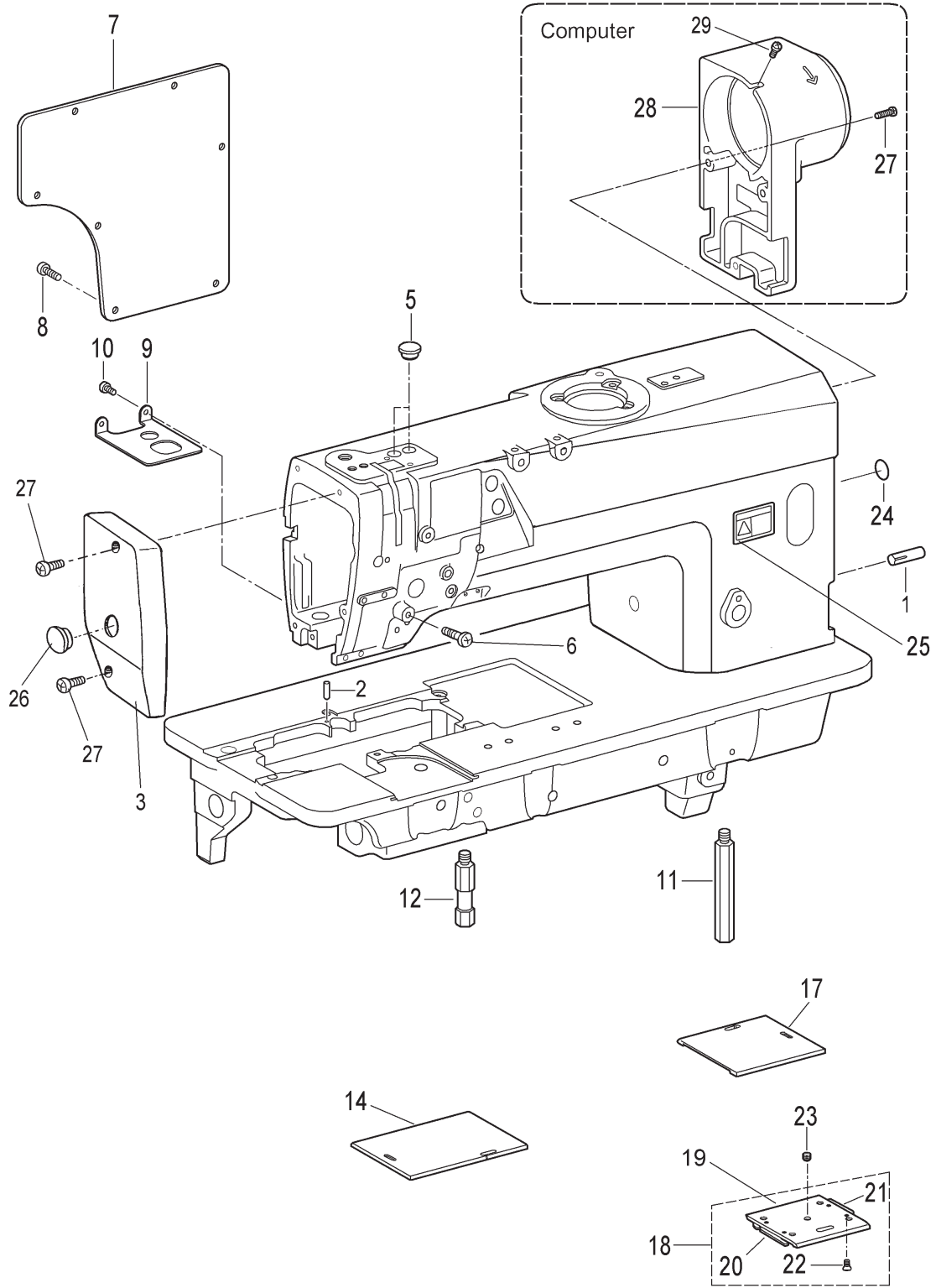

1-2.MACHINE BODY (9450、9750)

No.	Ref.No	Description	Qt	
1	B960047009	Dowel pin	1	
2	BXF7186009	Positioning pin	1	
3	216C10102	Face plate	1	
5	BXF8181009	Rubber plug 12.5	2	
6	B048500294	Screw M5X8	2	
7	216000002	Rear cover	1	
8	B048509894	Screw M5X12	1	
9	BXF6730009	Dust protector	1	
10	B048500494	Screw M5X6	2	
11	BXF8666009	Bed leg, L	1	
12	BXF8665009	Bed leg, S	1	
14	BXF8662009	Slide plate L	1	
17	BXF8650009	Slide plate R	1	
18	BX74447059	Slide plate assy, front	1	
24	036E02002	Label, grounding	1	
25	QT000015	Label, caution english	1	
26	B906661009	Rubber plug 15.5	1	
27	B048509694	Screw M5X14	3	
28	BXF8668009	Motor cover	1	
29	B048509094	Screw M5X10	1	

* The part circled by [] is supplied in complete set.

2. UPPER SHAFT MECHANISM

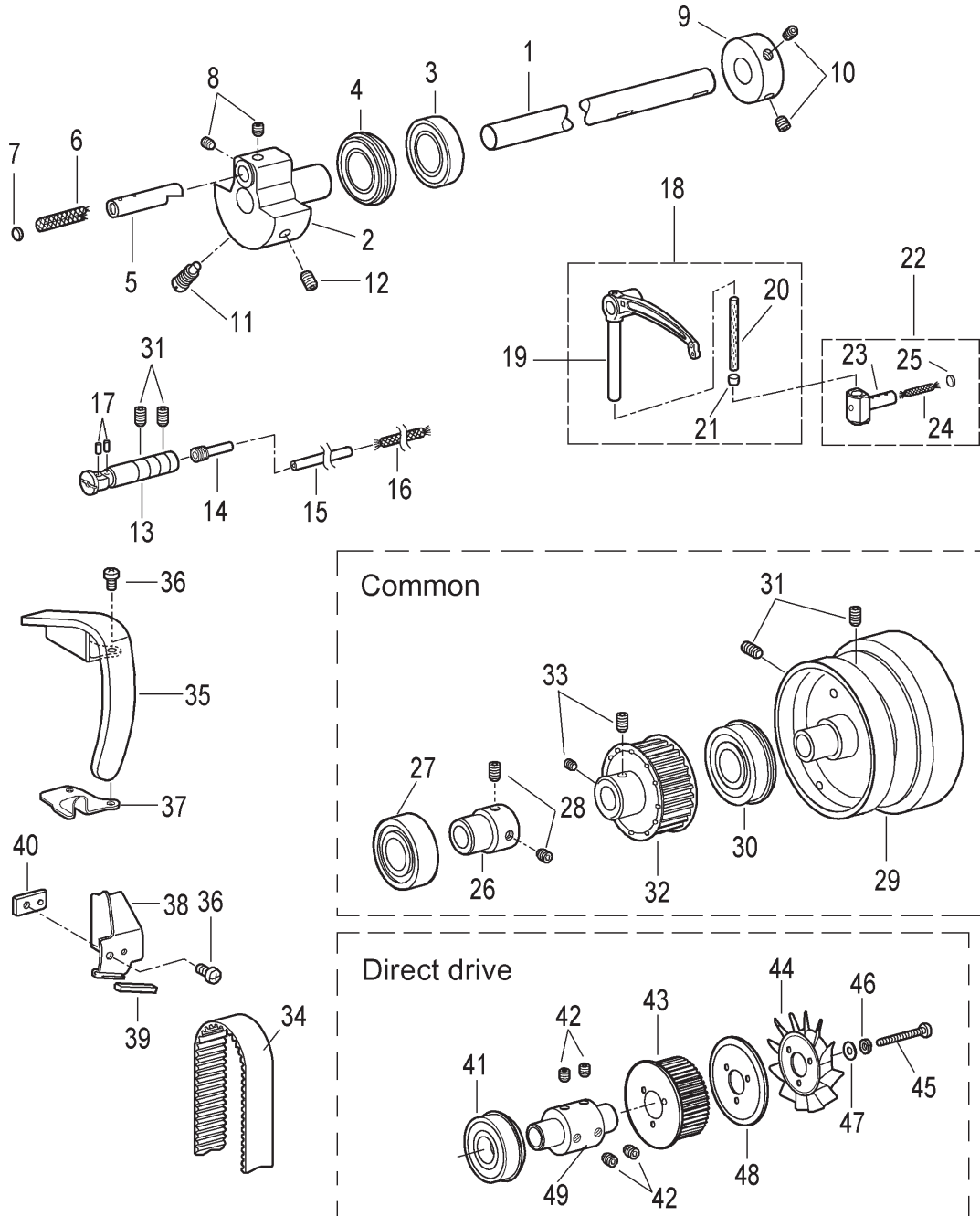

2. UPPER SHAFT MECHANISM

No.	Ref.No	Description	Qt	Note
1	BXF8364809	Upper shaft	1	9420/9720
	BXF6550009	Upper shaft	1	9450/9750
	BXF8658009	Upper shaft	1	With direct drive
2	BXF6021009	Needle bar crank	1	9420/9720
	BXF6737009	Needle bar crank	1	9450/9750
3	BX85876009	Ball bearing 6004ZZ	1	
4	S150866037	Ball bearing 6004ZZNR	1	
5	BX72712009	Needle bar Crank shaft	1	
6	BXF6775009	Wick 6X6 L=90	1	
7	B997096000	Wick cover	1	
8	BX85840009	Set screw M6X5	2	
9	BXF9980009	Friction-gear	1	
10	BX87459009	Set screw M6X6	2	
11	BX85875009	Screw M8	1	
12	BX85874009	Set screw M6X10	1	
13	BXF8645009	Pin	1	
14	BXF8247009	Tie-in of thread take-up lever shaft	1	
18	BXF8175909	Thread take-up lever assy	1	9420MD3 9450M/HD3
	BXF8174909	Thread take-up lever assy	1	9420M
	BXF8173909	Thread take-up lever assy	1	9450M/H 9420H 9420HD3
	BXF6742009	Thread take-up lever assy	1	9720M/HD3 9720M/H
19	BX72718009	Thread take-up lever	1	9750M/H 9750M/HD3
	BX72717009	Thread take-up lever	1	9420MD3 9450M/HD3
	BX72716009	Thread take-up lever	1	9420M
	BX72715009	Thread take-up lever	1	9450M/H 9420H 9420HD3
22	BX97940009	Sliding block assy	1	9720M/HD3 9720M/H
23	BX03772009	Sliding block	1	9750M/H 9750M/HD3
26	BXF8362009	Ball bearing bush	1	
27	B034087200	Ball bearing radial 60/22ZZ	1	
28	BX87459009	Set screw M6X6	2	
29	BXF8350009	Balance wheel	1	
30	S150866006	Ball bearing 6204ZZNR	1	
31	B098049074	Set screw M6X10	4	
32	BXF8380009	Timing pulley assy	1	
33	BX87459009	Set screw M6X6	2	
34	BXF8647009	Timing belt	1	
35	BXF8641009	Thread take-up lever cover	1	
36	B048500294	Set screw M5X8	3	
37	BXF7053009	Dust cover	1	
38	BXF7052909	Shelter plate	1	
	BXF6734909	Shelter plate	1	
39	BXF7045009	Felt	1	9420/9720
40	BXF7051009	Shelter plate holder	1	9450/9750
41	S150866006	Ball bearing 6004ZZNR	1	
42	BX87459009	Set screw M6X6	4	
43	BXF8649009	Timing pulley assy, Up	1	
44	BX72397900	Fan	1	
45	B048607598	Screw M4x35	3	
46	S8A3103011	Washer spring	3	
47	B085060878	Washer plain	3	
48	BXF8648009	Pulley flange	1	
49	BXF9969009	Coupling shaft organ	1	

* The part circled by [] is supplied in complete set.

3-1. NEEDLE BAR ROCKING MECHANISM (9420、 9720)

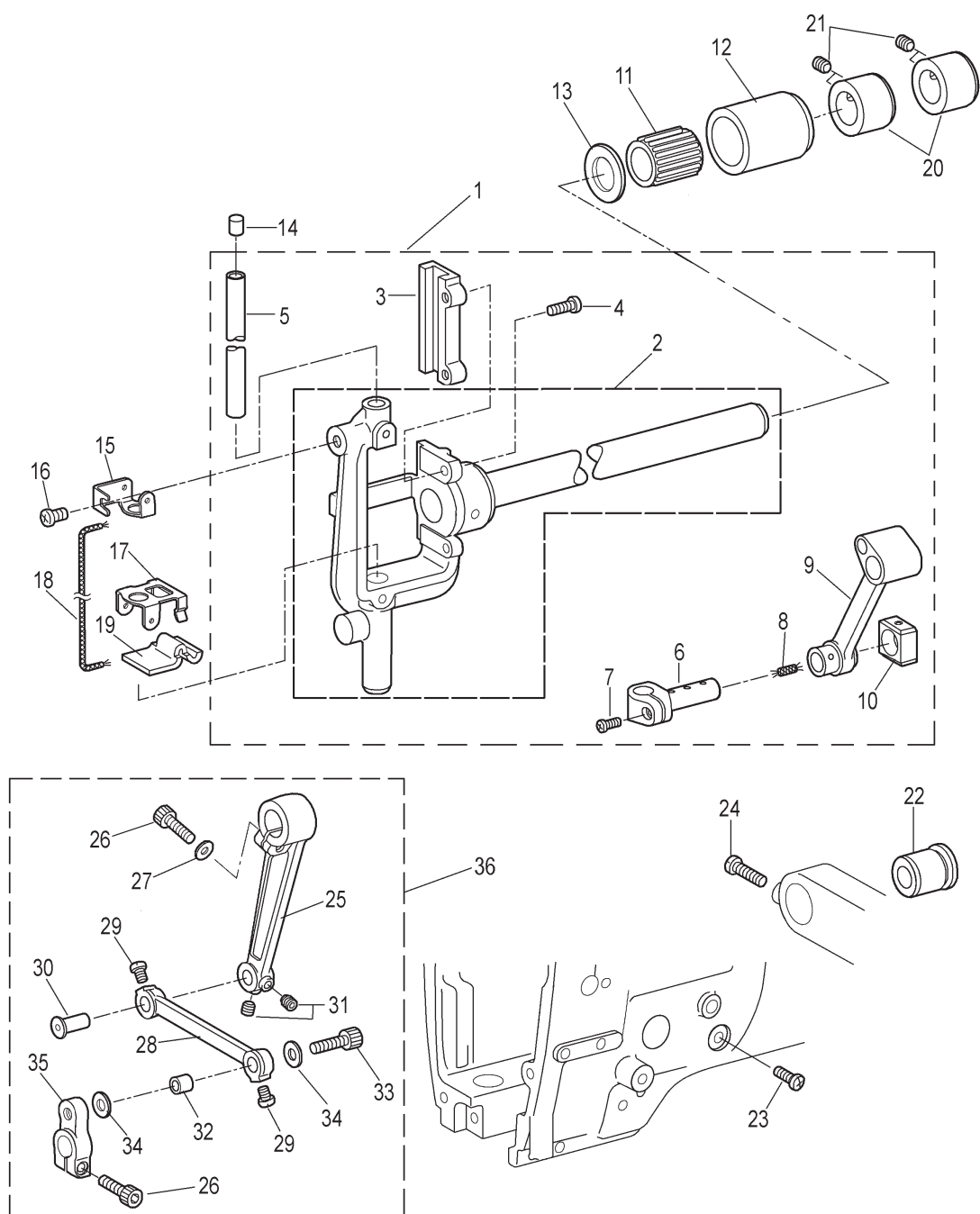

3-1. NEEDLE BAR ROCKING MECHANISM (9420、9720)

No.	Ref.No	Description	Qt	Note
1	BXF6986909	Needle bar rocker shaft assy	1	
2	BXF7256009	Needle bar support assy	1	
3	BXF8636809	Slide block slider	1	
4	B092609074	Screw M4X10	2	
5	BXF8635009	Needle bar	1	
6	BXF7390009	Needle bar clamp	1	
7	B048750294	Screw M3.5X8	1	
8	B998382009	Wick L=50	1	
9	BXF7399009	Needle bar crank rod	1	
10	BXF7398009	Slide block	1	
11	BXF8628009	Needle bearing	1	
12	BXF8627009	Case	1	
13	BXF8626009	Washer	1	
14	B962716000	Oil plug	1	
15	BXF6003009	Felt support, U	1	
16	B048500494	Screw M5X6	1	
17	BXF7262009	Felt support, D	1	
18	BX03645000	wick L=200	1	
19	BXF7258009	Felt	1	
20	BXF8625009	Set screw collar	2	
21	BX85840009	Set screw M6X5	4	
22	BXF8624909	Bush, R	1	
23	B048500294	Screw M5X8	1	
24	B048049494	Screw M6X16	1	
25	BXF8621009	Needle bar rocker lever, B	1	
26	B092048078	Bolt M6X20	2	
27	B992375008	Washer	1	
28	BXF8610009	Needle bar rocker lever, S	1	
29	BX87640009	Screw M6X5	2	
30	BXF6993009	Link shaft, P	1	
31	B098040474	Screw M6X6	2	
32	BXF6992009	Zigzag link bush, P	1	
33	B092048578	Bolt M6X25	1	
34	BXF8617009	Washer	2	
35	BXF8616009	Needle bar rock arm	1	
36	216301000	Needle bar rocker lever assy	1	

* The part circled by □ is supplied in complete set.

3-2. NEEDLE BAR ROCKING MECHANISM (9450、9750)

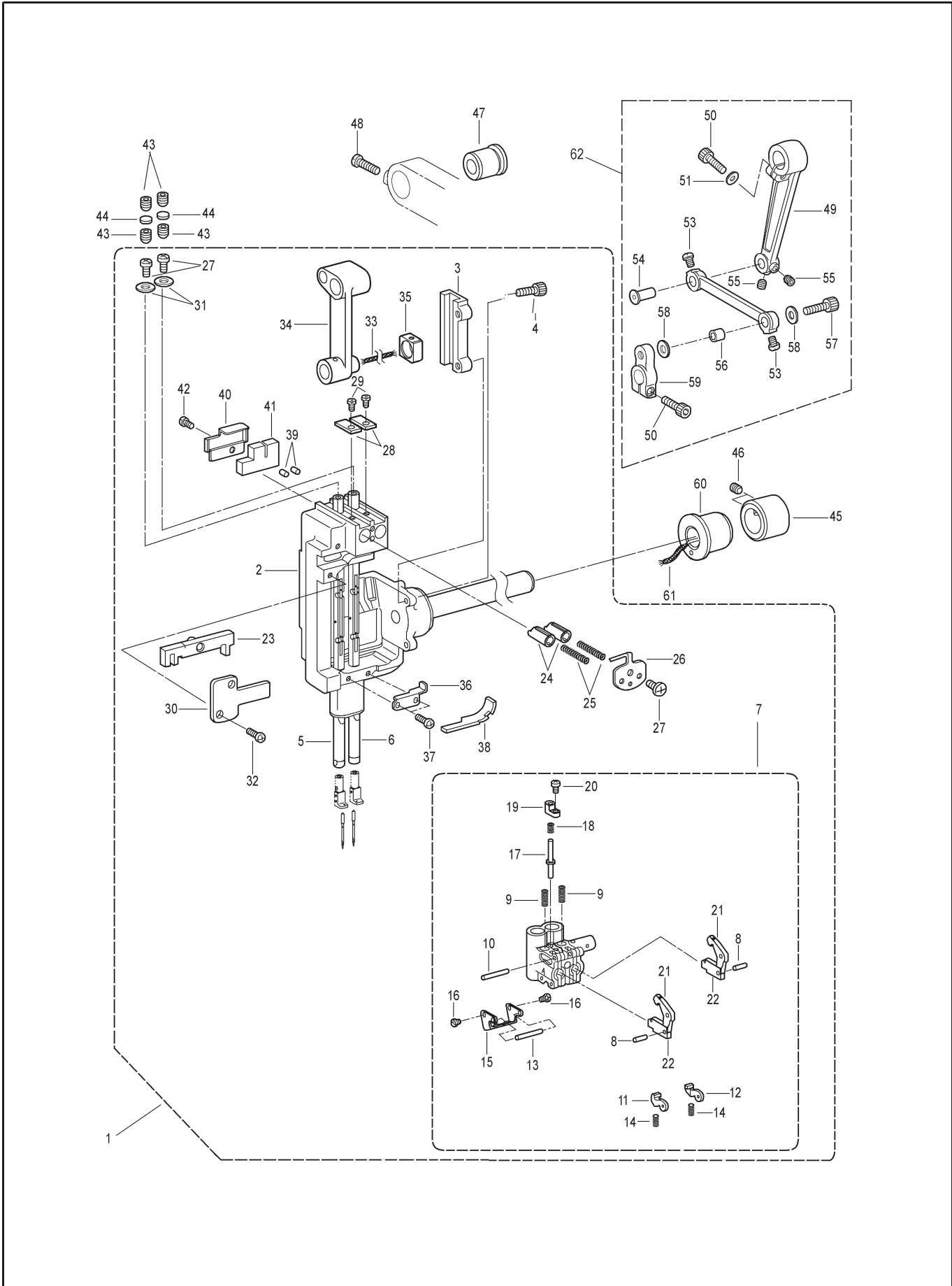

3-2. NEEDLE BAR ROCKING MECHANISM (9450、9750)

No.	Ref.No	Description	Qt	Note
1	BXF6733009	Needle bar rocker shaft assy	1	
2	BXF6732009	Needle bar base assy	1	
3	BXF8636809	Slide block slider	1	
4	B092609074	Bolt M4X10	2	
5	BXF6728009	Needle bar assy, L	1	
6	BXF6725009	Needle bar assy, R	1	
7	BXF6723009	Needle bar clamp assy	1	
8	B961406009	Pin 1.5x5.8	2	
9	B961405009	Clutch lever Spring	2	
10	B961283009	Pin 2x15.8	1	
11	BX76549009	Clutch stopper, L	1	
12	BX76548009	Clutch stopper, R	1	
13	B961402009	Pin 2x17.8	1	
14	B998401009	Spring	2	
15	BXF6719009	Spring holder	1	
16	B048840794	Screw M2.6x3	2	
17	B961490009	Pin	1	
18	B961499909	Spring	1	
19	BXF6718009	Pin cover	1	
20	B048840594	Screw M2.6x5	1	
21	B961408909	Clutch lever assy	2	
22	B961407009	Clutch stopper	2	
23	BX03535000	Slide block assy	1	
24	BXF6527009	Needle bar stopper	2	
25	B961488009	Needle bar stopper spring	2	
26	BXF6714009	Spring cover	1	
27	B040750494	Screw M3.5x6	3	
28	BXF6713009	Rotate stopper,N-bar	2	
29	BXF6712009	Screw SM3.5	2	
30	BXF6715009	Slide block guide plate	1	
31	BXF6711009	Washer	2	
32	B048750294	Screw M3.5x8	2	
33	B998382009	Wick L=50	1	
34	BXF6717009	Needle bar crank rod	1	
35	BXF6716009	Slide block	1	
36	BXF6609009	Felt support, D	1	
37	B048750494	Screw M3.5x6	2	
38	BXF6600009	Felt	1	
39	B903955009	Felt	2	
40	216C30001	Felt support	1	
41	BXF5873009	Felt	1	
42	B048750594	Screw M3.5x5	1	
43	B096020279	Set screw M8x8	4	
44	B922222089	Spacer 5.3	2	
45	BXF8625009	Set screw collar	1	
46	BX85840009	Set screw M6x5	2	
47	BXF8624909	Bush, R	1	
48	B048049494	Screw M6x16	1	
49	BXF8621009	Needle bar rocker lever assy	1	
50	B092048078	Bolt M6x20	2	
51	B992375008	Washer	1	
52	BXF8610009	Needle bar rocker link	1	
53	BX87640009	Screw M6x5	2	
54	BXF6993009	Needle bar rocker Link shaft, P	1	
55	B098040474	Set screw M6x6	2	
56	BXF6992009	Zigzag link bush, P	1	
57	B092048578	Bolt socket M6x25	1	
58	BXF8617009	Washer	2	
59	BXF8616009	Needle bar rock arm	1	
60	BXF5778009	Bush, L	1	
61	BX62806000	Wick 4x4 L=150	1	
62	216301000	Needle bar rocker lever assy	1	

* The part circled by □ is supplied in complete set.

4. NEEDLE BAR FLIP-UP MECHANISM (9450、 9750)

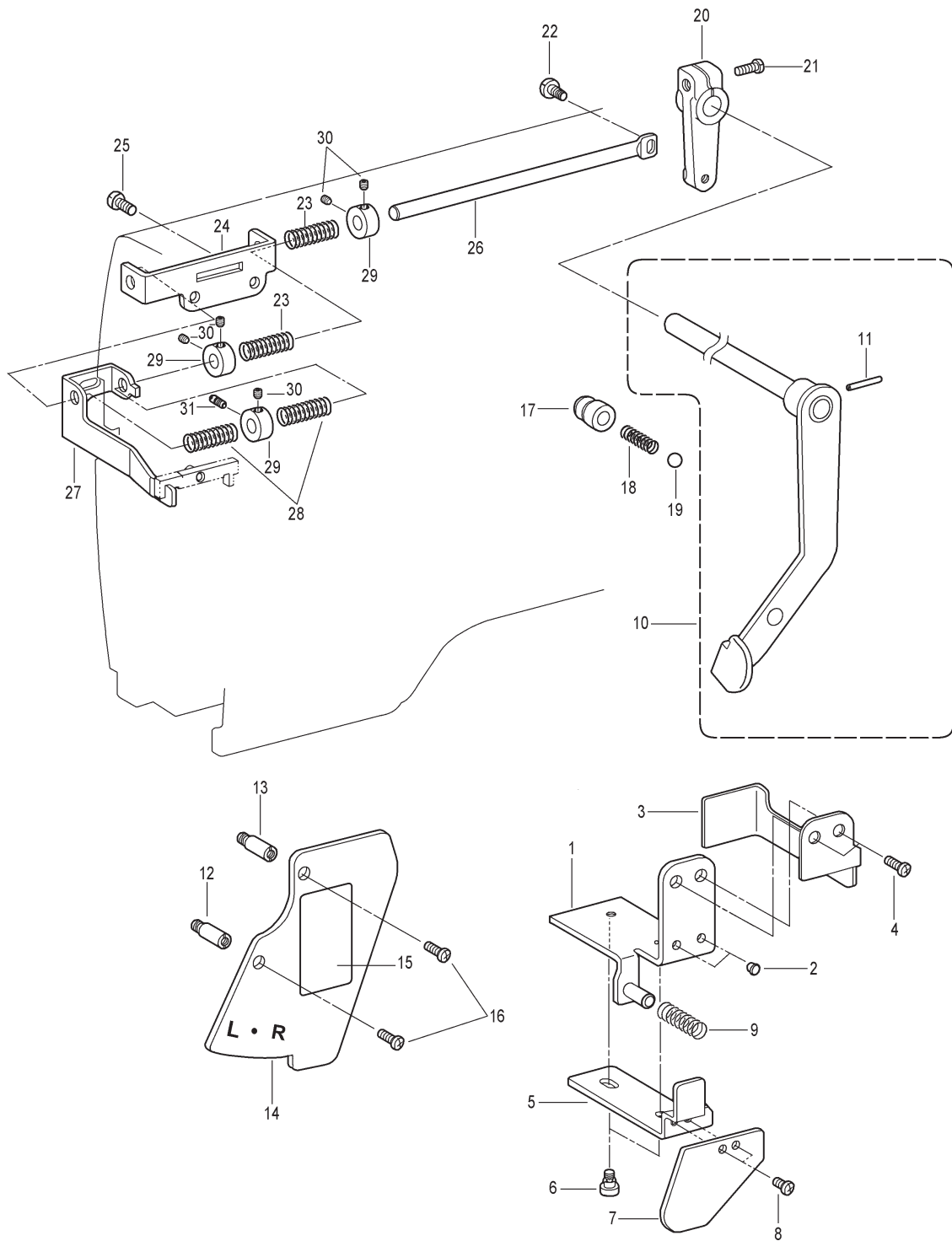

4. NEEDLE BAR FLIP-UP MECHANISM (9450、9750)

No.	Ref.No.	Description	Qt	Note
1	BXF6608009	Indication plate assy	1	
2	B906277009	Rubber plug 4.3	2	
3	BXF5774009	Holder plate cover	1	
4	B048509094	Screw M5x10	2	
5	BXF6606009	Push lever	1	
6	BXF6669009	Shoulder screw M4	2	
7	BXF6605009	Push lever plate	1	
8	B048750594	Screw M3.5x5	2	
9	BXF5777009	Spring	1	
10	BXF6604009	Stop lever shaft assy	1	
11	B063709268	Pin AW3x18	1	
12	BXF6602009	Stud, L	1	
13	BXF6601009	Stud, S	1	
14	BXF6699909	Flip-up holder plate	1	
15	B922222090	Label	1	
16	B048500294	Screw M5x8	2	
17	BXF6698009	Ball guide bush	1	
18	B950280009	Spring	1	
19	B039047550	Bearing ball 1/4	1	
20	BXF6697009	Lever shaft arm	1	
21	B048509694	Screw M5x14	1	
22	BX87337009	Screw M4	1	
23	BXF6696009	Spring	2	
24	BXF6695009	Slide shaft bracket	1	
25	B048500294	Screw M5x8	2	
26	BX03522009	Slide shaf	1	
27	BXF6694009	Support plate	1	
28	B961247009	Spring	2	
29	BXF6693009	Set screw collar	3	
30	B096600978	Screw M4x4	5	
31	BXF6692009	Guide screw	1	

* The part circled by □ is supplied in complete set.

5. AUTOMATIC RESET MECHANISM

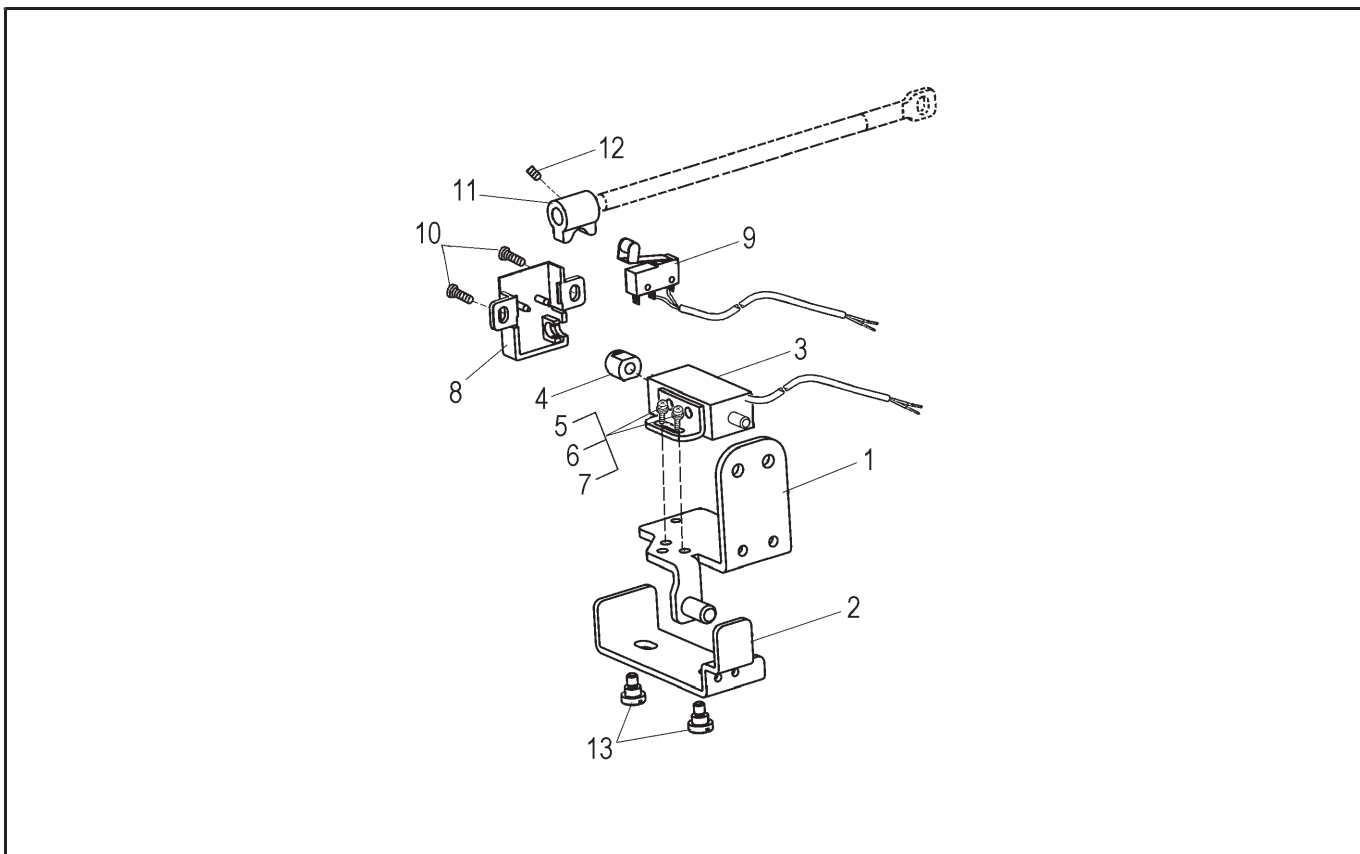

6. THREAD CLAMP MECHANISM

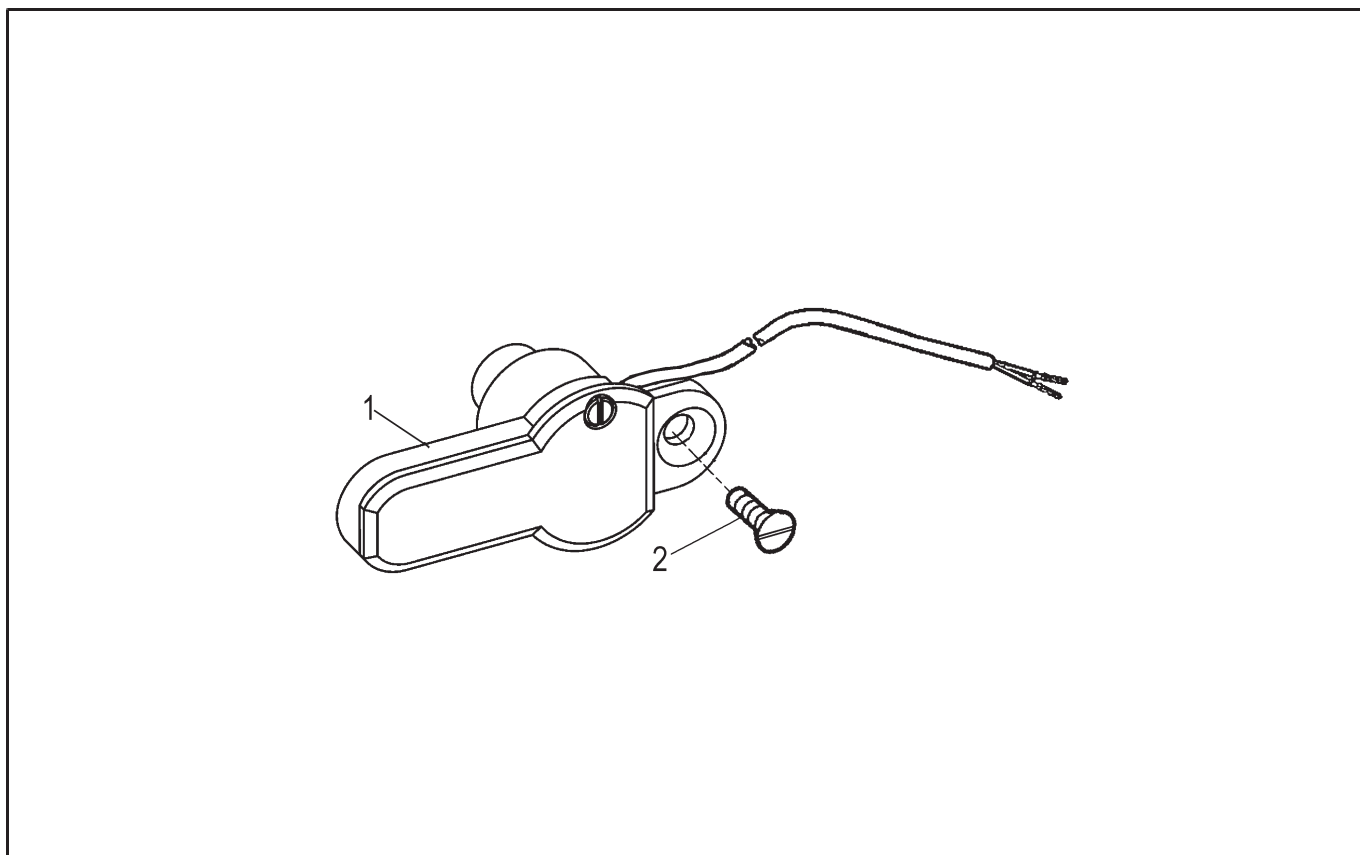

5. AUTOMATIC RESET MECHANISM

No.	Ref.No.	Description	Qt	Note
1	216V40001	Indication plate	1	
2	216V40002	Push lever	1	
3	216V40003	Solenoid	1	
4	500014307	Spacer	1	
5	B048600494	Screw M4 × 6	2	
6	S150602005	Washer spring GB859-76 Φ4	2	
7	217100024	Washer 4	2	
8	216V40004	Switch base	1	
9	216V41000	Micro switch assy	1	
10	B048600494	Screw M4 × 6	2	
11	216V40005	Bush	1	
12	B096600978	Screw M4 × 4	1	
13	BXF6669009	Screw M4	2	

6. THREAD CLAMP MECHANISM

No.	Ref.No.	Description	Qt	Note
1	216M10500	Thread trimmer solenoid assy	1	
2	BXF8460009	Screw M5 × 8	1	

* The part circled by □ is supplied in complete set.

7. PRESSER FOOT MECHANISM

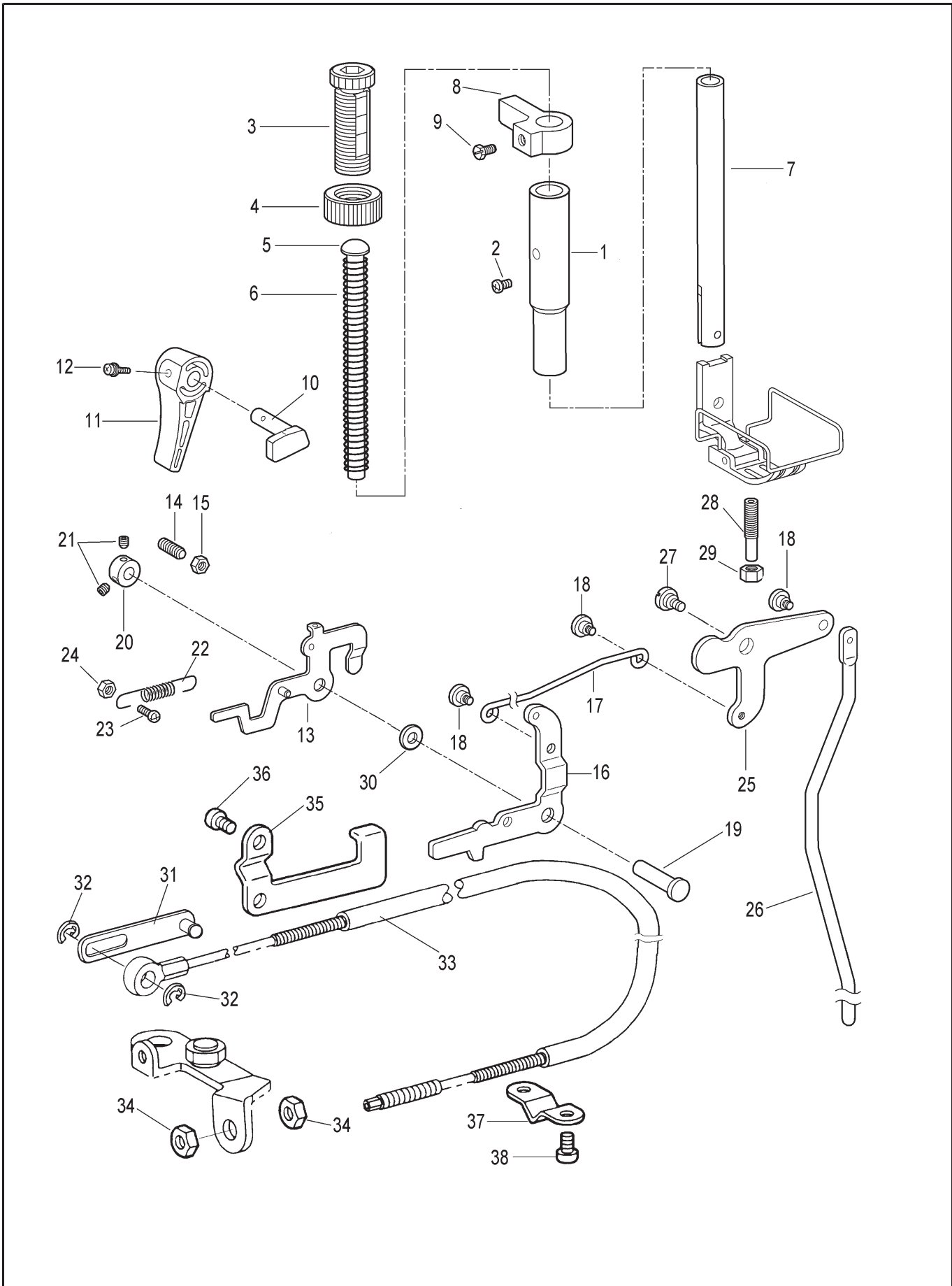

7. PRESSER FOOT MECHANISM

No.	Ref.No.	Description	Qt	Note
1	BXF8615009	Presser bar bush	1	
2	B048500294	Screw M5X8	1	
3	BXF9936009	Screw M14	1	
4	BXF9935009	Nut M14	1	
5	B969802009	Presser bar guide	1	
6	BX03764909	Presser spring	1	
7	BXF8614009	Presser bar	1	
8	BXF8612009	Presser bar guide bracket	1	
9	BX85821009	Bolt M6X10	1	
10	BXF8611009	Presser bar lifting crank	1	
11	BX79004009	lifting lever	1	
12	S150183001	Screw M3.5X12	1	
13	BX03757009	Tension release plate assy	1	
	BX03759009	Tension release plate assy	1	With direct drive
14	B098049278	Screw M6X18	1	
15	S150559002	Nut M6	1	
16	BXF8509009	Presser bar lifting lever	1	
17	BXF8508009	Knee lifter connecting rod	1	
18	BXF9931009	Shoulder screw M5	3	
19	BX03761009	Pin	1	
20	BXF8506009	Set screw collar	1	
21	B098500574	Screw M5X5	2	
22	BX03755059	Spring	1	
23	B048509694	Screw M5X14	1	
24	B089500904	Nut M5	1	
25	BXF8504009	Knee lifter lever	1	
26	BXF8503009	Knee lifter bar	1	
27	BXF8945009	Shoulder screw M6	1	
28	BXF6961009	Adjusting screw 6	1	
29	B089040704	Nut M6	1	
30	BX03750009	Washer	1	
31	BX03581009	T-release connecting rod assy	1	With direct drive
32	S4A0105006	Retaining ring E3	2	With direct drive
33	BXF8433009	Tension release wire	1	With direct drive
34	B990949006	Nut SM4.76	1	With direct drive
35	BXF8432009	Tension release wire holder	1	With direct drive
36	B048500294	Screw M5x8	2	With direct drive
37	BXF8431009	Tension release wire holder	1	With direct drive
38	B048040294	Screw M6x8	2	With direct drive

* The part circled by □ is supplied in complete set.

8. FEED MECHANISM

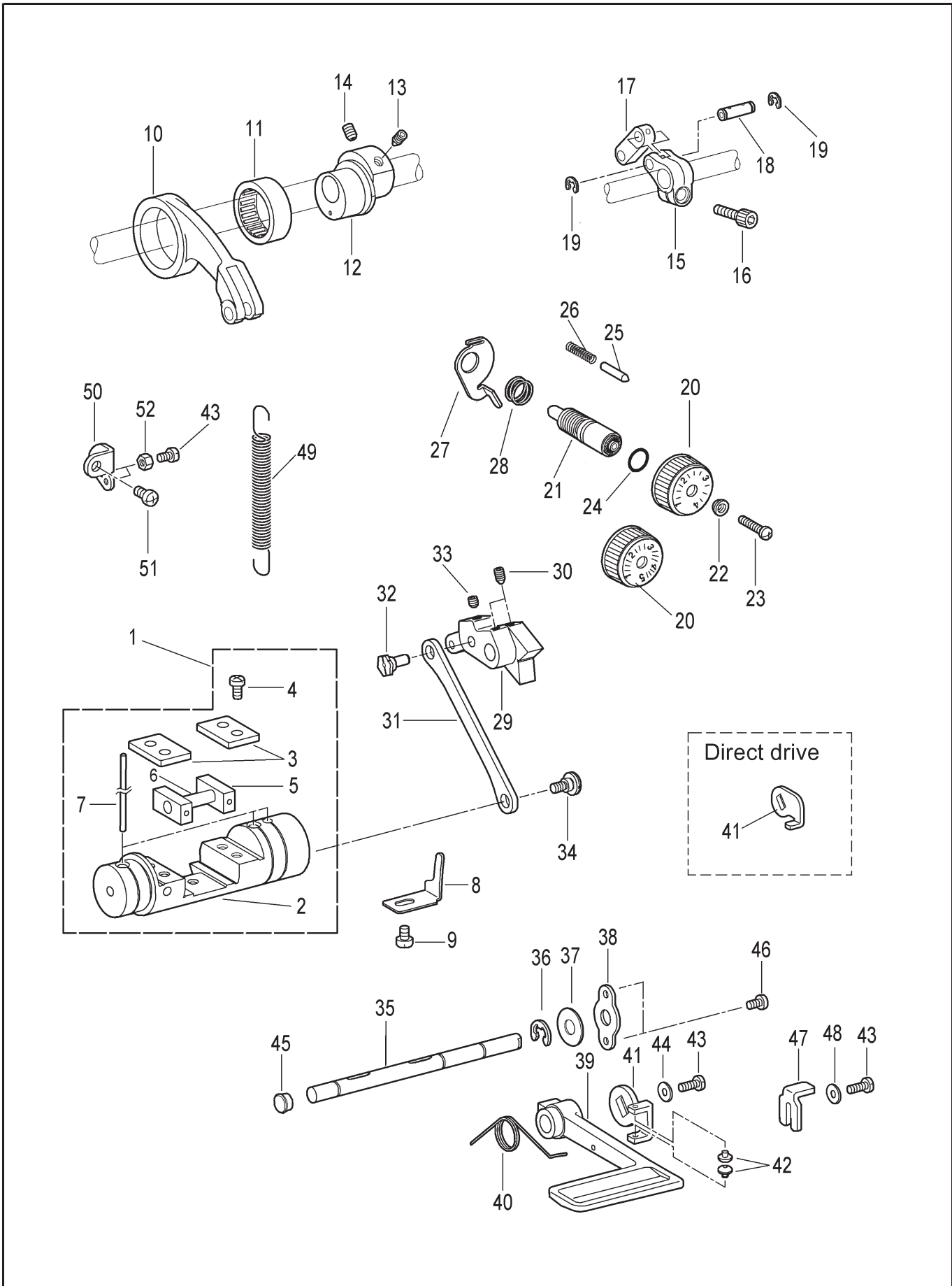

8. FEED MECHANISM

No.	Ref.No.	Description	Qt	Note
1	BXF7048009	Feed regulator assy	1	9420M/9720/9750/9420MD3
	BXF8501009	Feed regulator assy	1	9420H/9450/9420HD3
8	BXF8594009	Stopeer	1	
9	B048040294	Screw M6X8	1	
10	B967498900	Feed rocker connecting rod	1	
11	B992156000	Needle bearing	1	
12	BXF8592009	Feed cam 5	1	9420/9450
	BXF8319009	Feed cam 7	1	9720/9750
13	BXF8525009	Set screw M6X10	1	
14	BX85874009	Screw M6X10	1	
15	BXF8589009	Feed crank 5	1	9420/9450
	BXF8317009	Feed crank 7	1	9720/9750
16	B092048078	Bolt M6X20	1	
17	B967497059	Feed link	1	
18	B967494009	Shaft	1	
19	B062040768	Retaining ring E6	2	
20	BX72688002	Stitch length dial 4	1	9420M
	BX72683002	Stitch length dial 5	1	9420H 9450
	BX72682009	Stitch length dial 7	1	9720 9750
21	BXF7054009	Stitch length adjusting head screw	1	
22	B968364008	Bush	1	
23	B981652908	Srew SM4.76	1	
24	124510003	O ring	1	
25	BX50012909	Pin	1	
26	B900782009	Notch spring	1	
27	BXF8587009	Dial lock lever	1	
28	BX71270909	Spring	1	
29	BXF8585009	Stitch length dial 4	1	9420 9450
	BXF8314009	Stitch length dial 5	1	9720 9750
30	S150225003	Screw M6X10	2	
31	BXF8584009	Stitch length link	1	
32	BXF8583009	Eccentric shaft	1	
33	B098040474	Screw M6X6	1	
34	BXF8582909	Shoulder screw M6	1	
35	BXF8581909	Shaft TR	1	
36	B062020768	Retaining ring E8	1	
37	B085900978	Washer plain S10	1	
38	BXF8570009	Washer	1	
39	BX03736901	Reverse stitching lever	1	
40	BXF8579009	Spring	1	
41	BXF7043009	Lever guide	1	Without direct drive
	BXF8569009	Lever guide	1	With direct drive
42	BX62743000	Rubber	2	Without direct driv
43	B048509894	Screw M5X12	3	
44	B085050774	Washer plain M5	1	
45	B906289009	Rubber plug 10.5	1	
46	B048500294	Screw M5X8	2	
47	BXF8578009	Stopper	1	
48	B085050874	Washer plain M5	1	
49	BX03734009	Spring	1	
50	BXF8577009	Spring hook	1	
51	B048040294	Screw M6X8	1	
52	B089500904	Nut M5	1	

* The part circled by □ is supplied in complete set.

9. FEED SHAFT MECHANISM

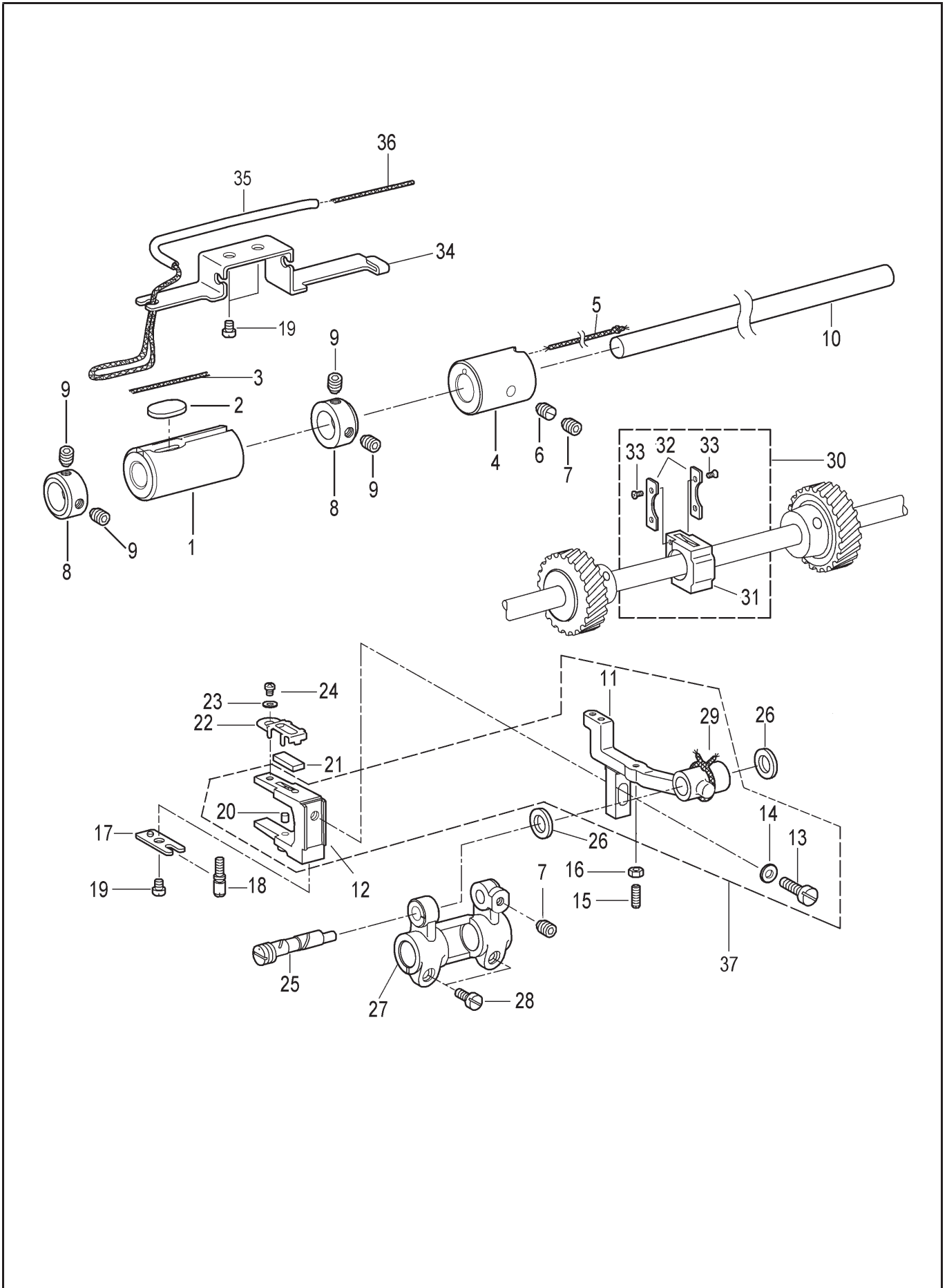

9. FEED SHAFT MECHANISM

No.	Ref.No.	Description	Qt	Note
1	BXF7255009	Feed rock shaft Bush L	1	
2	BXF7145009	Felt	1	
3	BXF6082009	Wick 4X4 L=450	1	
4	BXF8567009	Feed rock shaft Bush R	1	
5	B902208009	Wick 4X4 L=250	1	
6	BXF8566009	Screw M6	1	
7	B098040474	Screw M6X6	2	
8	BXF8564009	Set screw collar	2	
9	BX87459009	Screw M6X6	4	
10	BXF7260009	Feed rocker shaft	1	
11	BXF7246009	Feed bar	1	Without direct drive
	BXF7243009	Feed bar	1	With direct drive
12	BXF7224009	Feed forked connection	1	
13	BXF8183009	Screw M6X14	1	
14	B085040978	Washer S6	1	
15	BXF8544009	Screw M3.5	1	
16	B089750904	Nut 3.5	1	
17	BXF8557009	Forked plate	1	
18	BXF8556009	Adjusting screw, hight	1	
19	B048600494	Screw M4X6	3	
20	BXF7110009	Felt	1	
21	BXF7223009	Felt	1	
22	BXF7222009	Felt holder	1	
23	B085070978	Washer S3	1	
24	B048700694	Screw M3X4	1	
25	BXF8550009	Shaft for feed bar crank	1	
26	BXF8559009	Thrust ring	2	
27	BXF8555009	Feed rock shaft crank	1	
28	BXF8182009	Screw M5X12	2	
29	BXF6085009	Wick 4X4 L=180	1	
30	BXF8204009	Feed bar slide block assy	1	
34	BXF6001009	Wick support	1	
35	BXF6099009	Oil tube L=100	1	
36	BXF8386009	Wick 4x4 L=400	1	
37	BXF4958909	Feed bar assy	1	Without direct drive
	BXF4950909	Feed bar assy	1	With direct drive

* The part circled by [] is supplied in complete set.

10. ROTARY HOOK MECHANISM

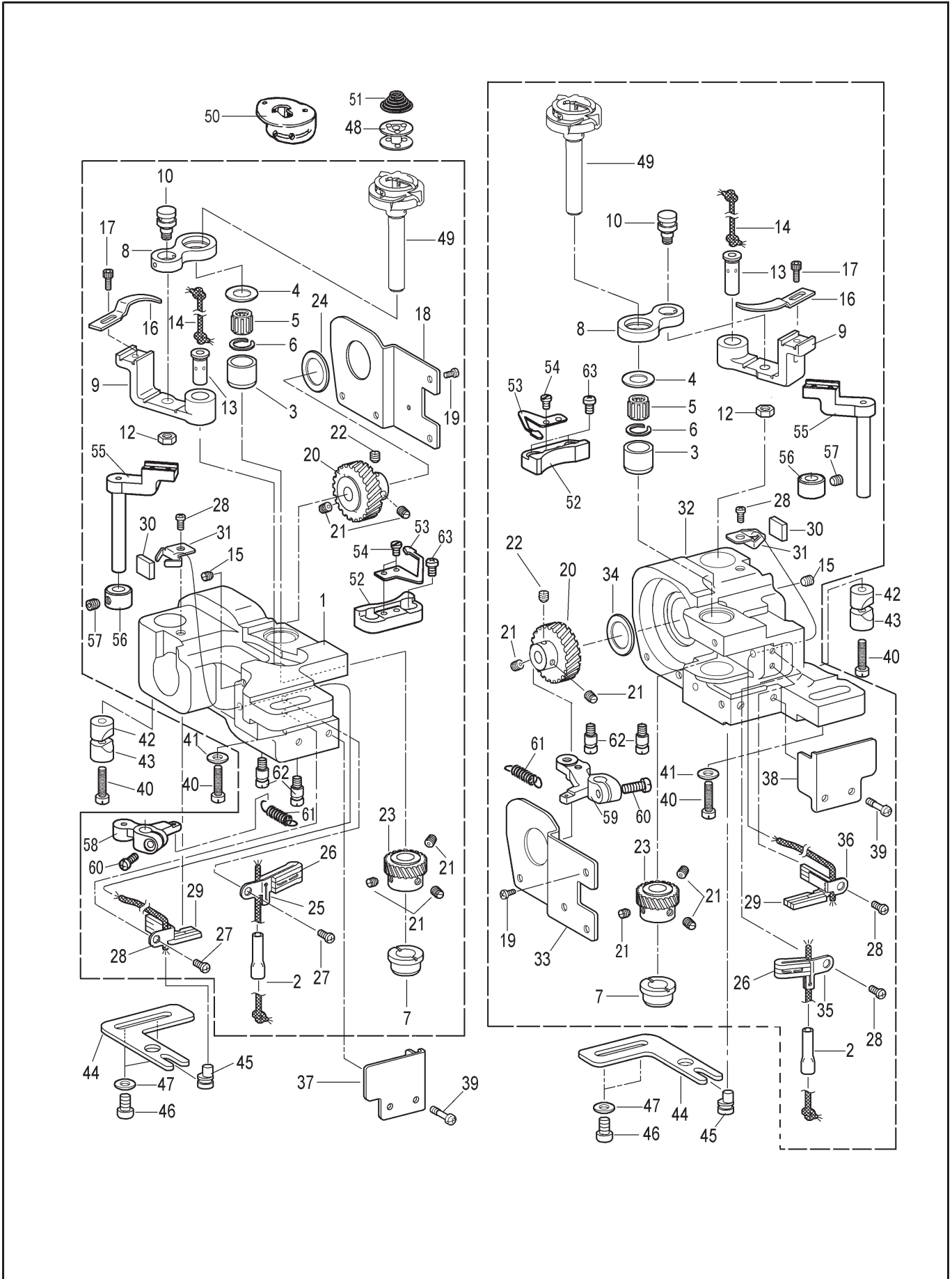

10. ROTARY HOOK MECHANISM

No.	Ref.No.	Description	Qt	Note
1	BXF7155009	Left hook saddle	1	9420M/H 9450M/H
	BXF7151009	Left hook saddle	1	9720M/H 9750M/H
	BXF7153009	Left hook saddle	1	9720M/HD3 9750M/HD3
	216P00001	Left hook saddle	1	9420M/HD3 9450M/HD3
2	BXF7149009	Pipe	2	
3	BXF6081009	Rotary hook shaft bush, U	2	9420/9450
	BX01851009	Rotary hook shaft bush, U	2	9720/9750
4	BX01840009	Thrust ring, A 1.2MM	2	
	BXF6072009	Thrust ring, 1.0MM	2	
	BX01849009	Thrust ring, B 1.4MM	2	
	BXF6666009	Thrust ring, B 0.8MM	2	
5	BX03680000	Needle bearing	2	
6	BX03691009	Retaining ring	2	
7	BXF8553009	Rotary hook shaft bush, D	2	
8	B998418909	Opener link	2	9420/9450
	B950143909	Opener link	2	9720/9750
9	BXF7251009	Opener lever	2	9420/9450
	BXF7249009	Opener lever	2	9720/9750
10	BXF8540009	Shaft	2	
12	B089500794	Nut M5	2	
13	BXF7221909	O-lever shaft	2	
14	BXF6084009	Wick 4X4 L=100	2	
15	B098500574	Screw M5X5	2	
16	BX72898009	Opener	2	
17	B956145009	Screw SM3.57X8	2	
18	BXF8548909	Rotary hook base cover, L	1	
19	B048700498	Screw M3X6	8	
20	216000014	Spiral gear screw assy, B	2	
21	BXF8536009	Screw M6	10	
22	BXF8535009	Screw M6	2	
23	216000015	Spiral gear screw assy, S	2	
24	BXF7056009	Washer, L	1	
25	BXF7218009	Felt support, UL	1	
26	BXF7217009	Felt	2	
27	B048600494	Screw M4X6	6	
28	BXF7148009	Felt support, DL	1	
29	BXF7146009	Felt	2	
30	BXF6098009	Felt	2	
31	BXF7216009	Felt support	2	
32	BXF7154009	Right hook saddle	1	9420M/H 9450M/H
	BXF7140009	Right hook saddle	1	9720M/H 9750M/H
	BXF7152009	Right hook saddle	1	9720M/HD3 9750M/HD3
	216P00002	Right hook saddle	1	9420M/HD3 9450M/HD3
33	BXF8547909	Rotary hook base cover, R	1	
34	BXF8531009	Washer	1	

* The part circled by □ is supplied in complete set.

10. ROTARY HOOK MECHANISM

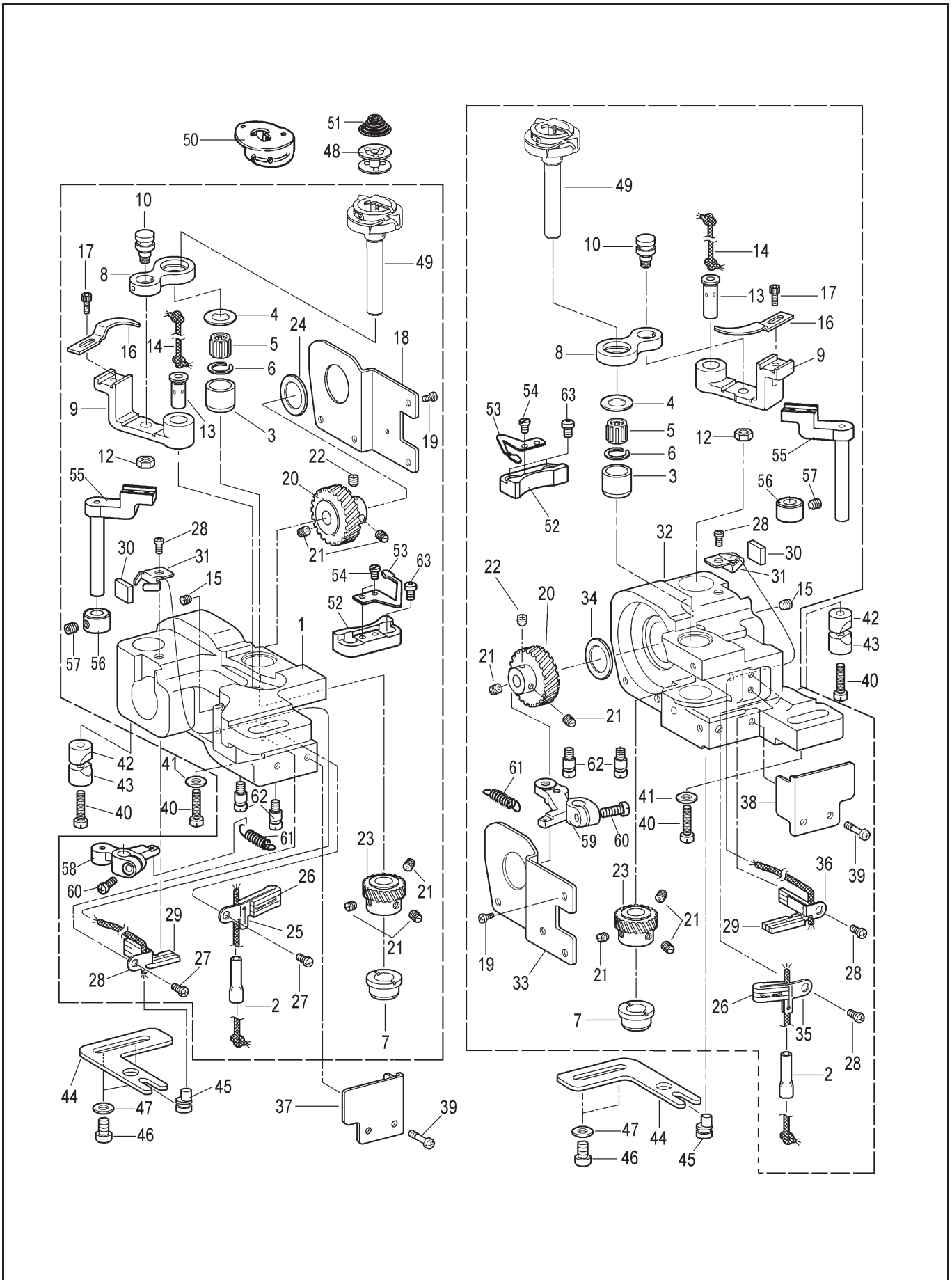

10. ROTARY HOOK MECHANISM

No.	Ref.No.	Description	Qt	Note
35	BXF7196009	Felt support, UR	1	
36	BXF7147009	Felt support, DR	1	
37	BXF7122009	Rotary hook base cover, FL	1	
38	BXF7194009	Rotary hook base cover, FR	1	
39	BXF8285009	Screw M4X12	4	
40	BXF8554009	Screw M6X25	4	
41	B995163009	Washer 6.35	2	
42	BXF8388009	Bush, U	2	
43	BXF8545009	Bush, D	2	
44	BXF8543009	Needle upper positioning plate	2	
45	BXF8542009	Needle upper positioning shaft	2	
46	B048049094	Screw M6X10	4	
47	B085040974	Washer S6	4	
48	BX09182959	Bobbin	2	9420/9450
	BX01825059	Bobbin	2	9720/9750
49	BX03685999	Rotary hook assy	2	9420M
	BX03684999	Rotary hook assy	2	9420H
	BX03542199	Rotary hook assy	2	9450M/H
	BX01847908	Rotary hook assy	2	9720M/H
	BX01845908	Rotary hook assy	2	9750M/H
	BX01846908	Rotary hook assy	2	9720M/HD3
	BX01844908	Rotary hook assy	2	9750M/HD3
	BX03681999	Rotary hook assy	2	9420M/HD3
	BX03541999	Rotary hook assy	2	9450M/HD3
50	BX03360009	Bobbin bush	2	9420M/HD3
	BX03369009	Bobbin bush	2	9450M/H
	BX01831009	Bobbin bush	2	9750M/H
	BX03368009	Bobbin bush	2	9450M/HD3
	BX01832009	Bobbin bush	2	9720M/HD3
	BX01820009	Bobbin bush	2	9750M/HD3
51	B962408009	Bobbin spring	2	9420M/HD3 9450M/HD3
	B954553009	Bobbin spring	2	9720 9750
	BX01824000	Bobbin spring	2	9720M/HD3 9750M/HD3
52	BXF8434009	Movable knife bracket	2	With direct drive
53	BX03585009	Spring	2	With direct drive
54	B969566009	Screw SM3.18-40x3	4	With direct drive
55	BXF7198009	Movable knife lever	2	With direct drive
56	BXF8435009	Set screw collar	2	With direct drive
57	BX87459009	Set screw M6x6	2	With direct drive
58	BXF8439009	Thread trimmer lever L	1	With direct drive
59	BXF8430009	Thread trimmer leverR	1	With direct drive
60	B048509894	Screw M5x12	2	With direct drive
61	BXF8284009	Spring	2	With direct drive
62	BXF8393009	Stopper screw	4	With direct drive
63	B62400812	Screw M4x8	4	With direct drive

* The part circled by □ is supplied in complete set.

11. GAUGE PARTS

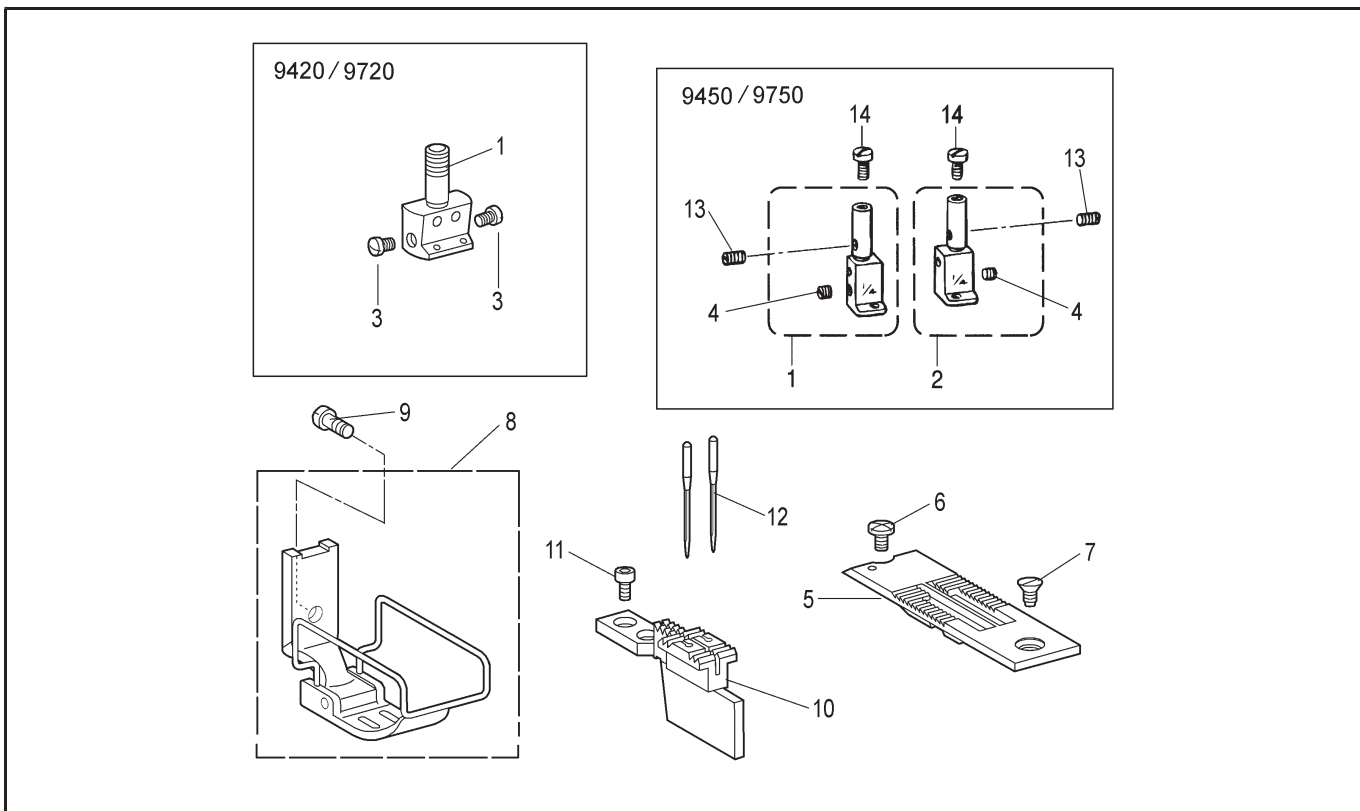

12. LOWER SHAFT MECHANISM

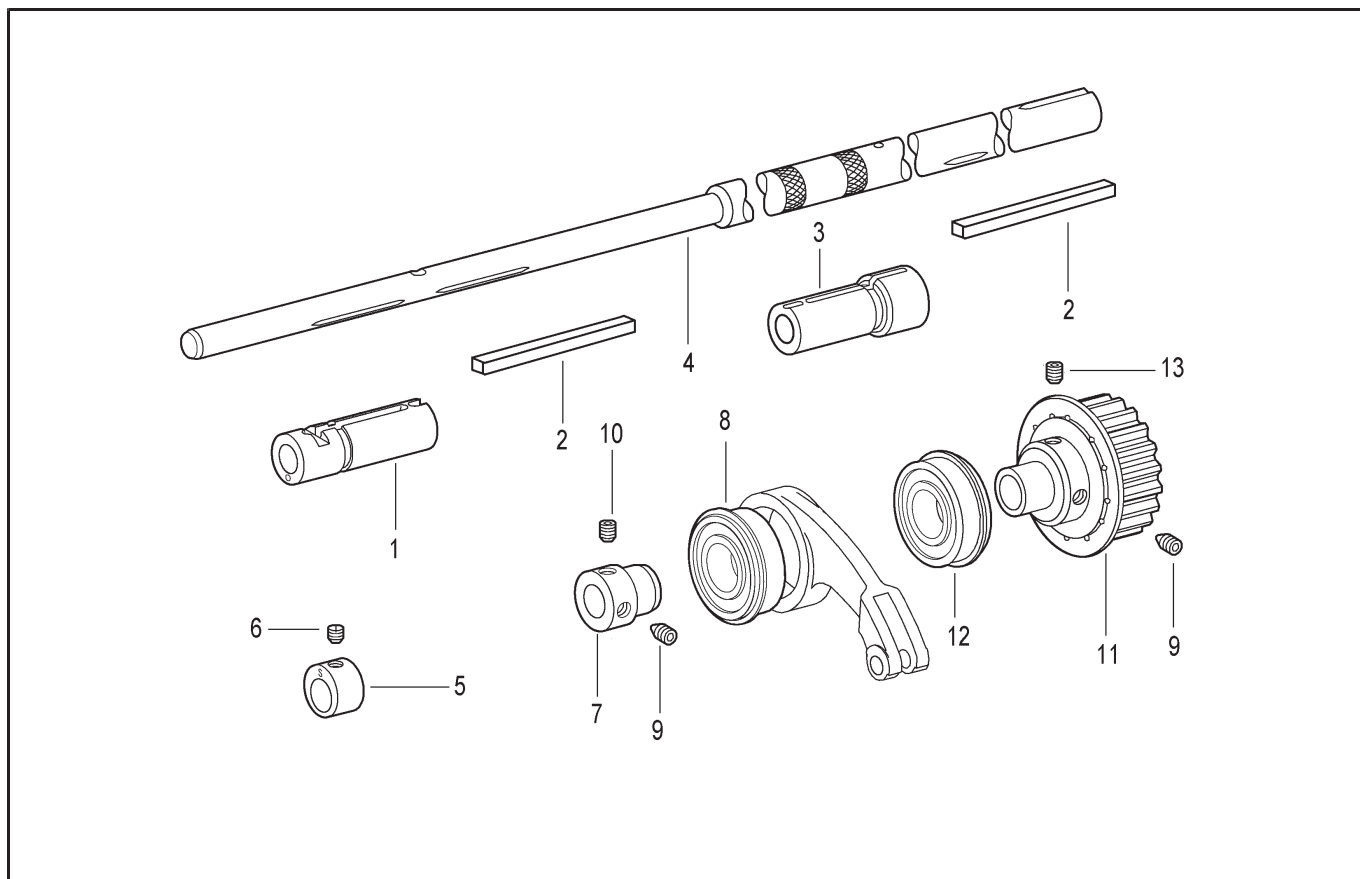

11. GAUGE PARTS

No.	Ref.No.	Description	Qt	Note
1	B998400009	Needle clamp 1/4	1	9420/9720
	BX95373009	Left Needle clamp assy	1	9450/9750
2	BX95372009	Right Needle clamp assy	1	9450/9750
3	B994787009	Screw SM3.57	2	9420/9720
4	B097440698	Screw SM3.18x4	2	9450/9750
5	B993743009	Needle plate 1/4	1	9420H 9450M/H 9720M/H 9750M/H
	B998406009	Needle plate 1/4	1	9420M
	B955257009	Needle plate 1/4	1	9450M/HD3 9720M/HD3 9750M/HD3 9420HD3
	B952327009	Needle plate 1/4	1	9420MD3
6	BX99866009	Screw SM4.37	1	
7	B900078006	Screw SM4.37-40X8 M H	1	
8	BXF6061009	Presser foot assy	1	9420M/H 9450M/H
	BXF6058009	Presser foot assy	1	9720 9750
	BXF6059009	Presser foot assy	1	9420MD3 9450MD3
	BXF6050009	Presser foot assy	1	9420HD3 9450HD3
9	216000017	Screw SM3.5	1	
10	B998440009	Feed dog 1/4	1	Without direct drive
	B962305009	Feed dog 1/4	1	MD3
	216M00002	Feed dog 1/4	1	HD3
11	BX03616009	Screw SM3.18X7	2	
12	058310010	Needle DP X5 14#	2	With M / MD3
	048200005	Needle DP X5 18#	2	With H / HD3
13	BX97025009	Screw SM3.18x4	2	
14	B961279909	Screw SM3.18	2	

12. LOWER SHAFT MECHANISM

No.	Ref.No.	Description	Qt	Note
1	BXF7210009	Bush, L	1	
2	BX72629000	Felt	2	
3	BXF7219009	Bush, R	1	
4	BXF8539009	Lower shaft	1	
5	BXF8340009	Feed dog lift cam	1	Without direct drive
	BXF8529009	Feed dog lift cam	1	With direct drive
6	BXF8535009	Screw M6	1	
7	BXF8526009	Ball bearing bush	1	
8	S150866037	Ball bearing 6004ZZNR	1	
9	BXF8525009	Set screw M6X10	2	
10	BX85874009	Screw M6X10	1	
11	BXF8523009	Timing pulley assy, D	1	
12	S150866006	Ball bearing, 6204ZZNR	1	
13	BXF6897009	Set screw M6X10	1	

* The part circled by □ is supplied in complete set.

13. LUBRICATION

No.	Ref.No.	Description	Qt	Note
1	BXF6805009	Oil tank assy	1	
4	BXF7060009	Oil feeding mouth 8.6	3	9450/9750 Qt. 4
5	B092029874	Bolt M8X12	1	9420/9720
6	BXF7164009	Oil terminal	1	
7	BXF8154009	Oil tube L=135	1	9450/9750 Qt. 2
8	BXF8153009	Felt	2	9450/9750 Qt. 4
9	B048500294	Screw M5X8	1	
10	BXF8181009	Rubber plug 12.5	3	9450/9750 Qt. 4
11	BX72844000	Felt	1	9450/9750 Qt. 2
12	BXF6895009	Felt assy	1	9420/9720
	BXF5886009	Felt assy	1	9450/9750
13	216000007	Wick 1100	1	
14	216000008	Oil tube 380	1	
15	BXF6077009	Felt support	1	
16	W060402029	Nylon string 3 X80	2	9450/9750 Qt. 3
17	B906650909	Rubber plug 8	2	
18	B029072030	O ring P38	1	
19	BXF8387009	Oil tube L=210	1	
20	BXF8386009	Wick L=400	1	
21	S150182001	Bolt M5X10DB	2	
22	BXF7214009	Oil block, L	1	
23	BXF8511009	Oil adjusting screw	2	
24	B029006030	O ring P4	2	
25	BXF7963009	Oil feeding pipe 2.5	4	
26	BXF7212009	Oil block, R	1	
27	B048049094	Screw M6X10	3	
28	B085040874	Washer M6	1	
29	BXF7049009	Rubber packing	2	
30	BXF8383909	Rotary hook shaft felt	2	
31	BX05864000	Felt	2	
32	BXF6502009	Tube clip	4	
33	B960783009	Rubber cap 6.3	2	
34	B968836909	Rubber cap 4.2	2	
40	BXF7073009	Sub-tank assy	1	
41	BXF7040009	Valve packing	1	
42	BXF8514009	Oil tube L=400	1	
43	BXF8513009	Oil tube L=500	1	
44	BXF8512009	Felt	1	
45	S150182002	Screw pan M4X8DA	2	
46	BXF7065909	Sub-tank setting plate, A	1	
47	BXF7064009	Sub-tank setting plate, B	1	
48	B048040294	Screw M6X8	2	
49	BXF7066009	Oil tube, L=242	1	
50	BXF7055909	Tube clip	4	9450/9750 Qt. 6
51	BXF7063009	Tube support	1	
52	BXF7187009	Rotary hook base packing	2	
53	B048609494	Screw M4X16	5	
54	BXF8406009	Felt	1	
55	BXF8405009	Felt plate	1	
56	B048500494	Screw M5X6	1	
57	BXF6084009	Wick 4X4 L=100	1	
58	B902209009	Wick 4X4 L=350	1	
59	BXF8404909	Box	1	
60	BXF7062909	Tube support A	1	
61	BXF7061009	Tube support B	1	
62	BXF6096009	Tube guide	1	
63	B960210001	Oil cap	1	
64	B998357009	Felt	2	
65	BXF5956009	Oil support	1	9450 9750
66	B048509094	Screw M5x10	1	9450 9750
67	BX61487000	Oil tube L=280	1	9450 9750
68	BX62910000	Wick 4X4 L=380	1	9450 9750
69	216000022	Plunger	2	

* The part circled by □ is supplied in complete set.

14. THREADING MECHANISM

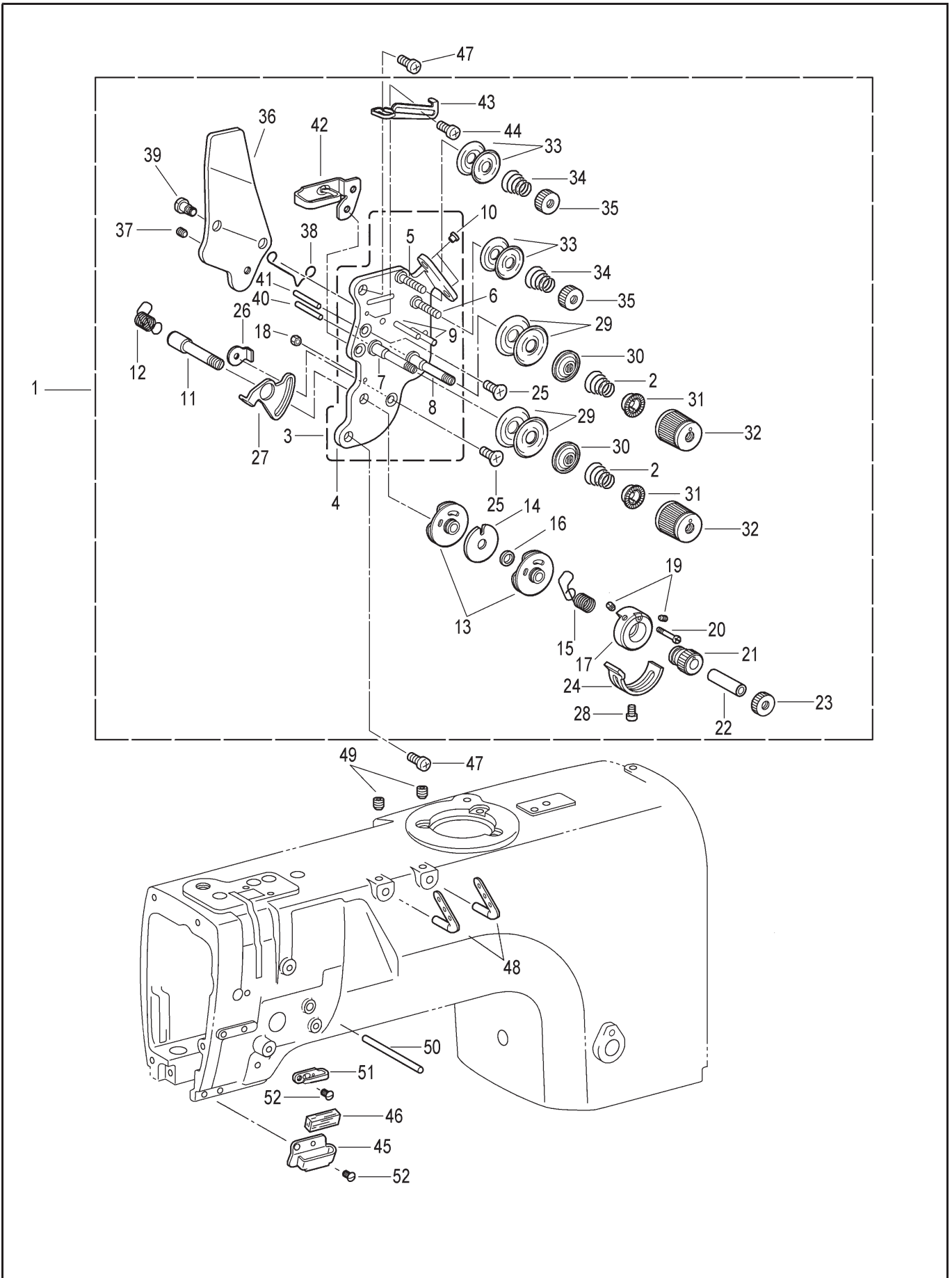

14. THREADING MECHANISM

No.	Ref.No.	Description	Qt	Note
1	BXF7693009	Thread tension assy	1	For M
	BXF8403009	Thread tension assy	1	For H
2	BXF7695009	Spring	2	For M
	BXF7694009	Spring	2	For H
3	BXF6898009	Tension set plate	1	
11	BXF8497009	Tension stud	1	
12	BXF8496009	Spring, L	1	
13	BXF8495009	Guide assy	2	
14	BXF8491009	Spacer	1	
15	BXF8487009	Spring, R	1	
16	BXF8480009	Collar	1	
17	BXF8489009	Stopper support	1	
18	B089700904	Nut M3	1	
19	BXF8484009	Screw M3.5	2	
20	BXF8486009	Set screw	1	
21	BXF8485009	Adjusting thumb	1	
22	BXF8483009	Collar	1	
23	BXF8482009	Nut	1	
24	BXF8481009	Stopper	1	
25	B049750494	Screw M3.5 X6	3	
26	BXF8286009	Nut M3.5	1	
27	BXF8470009	Stopper	1	
28	B048750598	Screw M3.5X5	1	
29	B965664009	Disc	4	
30	B951205009	Tension disc presser	2	
31	BX80429000	Washer	2	
32	BX80428905	Tension nut	2	
33	B966506009	Thread guide disc	4	
34	B956540009	Pre-tension spring, A	2	
35	B955590009	Tension nut	2	
36	BXF8478009	Tension release plate	1	
37	B098500574	Screw M5X5	1	
38	BX72836009	T-release spring	1	
39	BXF8477009	Screw M3.5	2	
40	BXF6504009	Tension release pin, L	1	
41	BXF6503009	Tension release pin, R	1	
42	BXF8476009	Thread guide, U	1	
43	BXF8475009	Thread quantity adjust	1	
44	B048700494	Screw M3X6	1	
45	BXF8471009	Thread guide, D	1	Without direct drive
46	B996169009	Felt	1	
47	B048500294	Screw M5X8	2	
48	BXF8474009	Thread retainer	2	
49	B098049074	Screw M6X10	2	
50	BXF8473009	Tension release bar	1	
51	BXF8472009	Thread guide, M	1	With direct drive Qt. 2
52	BXF8460009	Screw M5X8	2	

* The part circled by [] is supplied in complete set.

15. THREAD TRIMMER MECHANISM D3

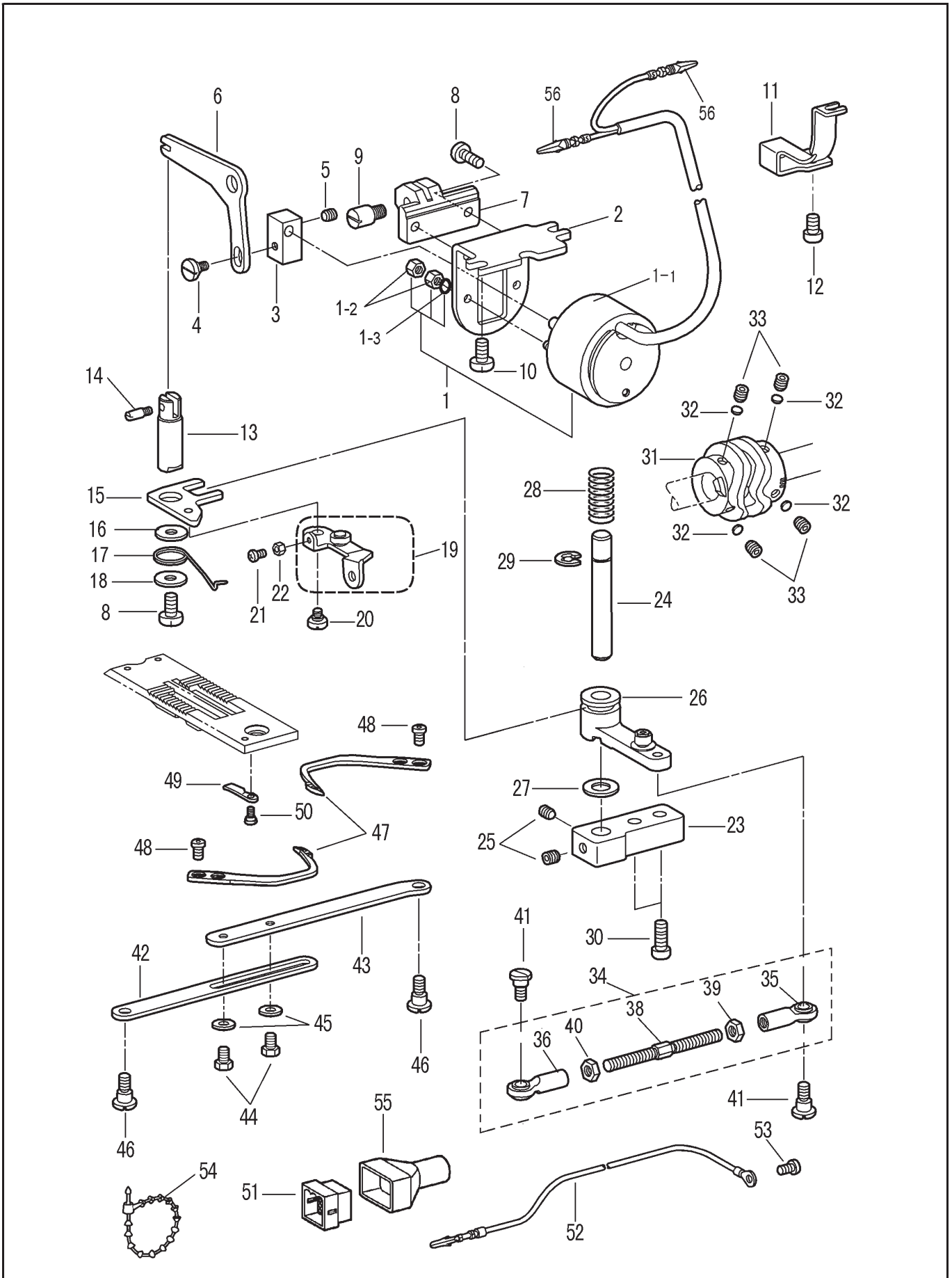

15. THREAD TRIMMER MECHANISM D3

No.	Ref.No.	Description	Qt	Note
1	BXF8468009	Thread trimmer solenoid assy	1	
1-1	BXF5469009	Solenoid	1	
1-2	S120501003	Nut M4	2	
1-3	S8A3103011	Washer	2	
2	BXF8467009	Thread trimmer solenoid bracket	1	
3	BXF8466009	Solenoid joint	1	
4	BXF8465009	Shoulder screw M5	1	
5	B098500574	Screw M5X5	1	
6	BXF8464009	Solenoid lever	1	
7	BXF8382009	Solenoid lever racket	1	
8	B048509094	Screw M5X10	3	
9	BXF8463009	Solenoid lever shaft	1	
10	B048049094	Screw M6X10	2	
11	BXF8462009	Cord holder	1	
12	B048040294	Screw M6X8	1	
13	BXF8459009	Driving rod	1	
14	B962564009	Pin	1	
15	BXF8458909	Driving rod plate	1	
16	BXF8240009	Washer	1	
17	BXF8251000	Spring	1	
18	B994448009	Washer	1	
19	BXF8457009	Tension release lever assy	1	
20	BXF8455009	Screw M4	1	
21	B048759894	Screw M3.5X12	1	
22	B089750904	Nut M3.5	1	
23	BXF8453009	Main lever support shaft	1	
24	BXF8452009	Main lever shaft	1	
25	B098040474	Screw M6X6	2	
26	BXF8451009	Main lever assy	1	
27	B962551900	Rubber washer	1	
28	BX03501009	Spring	1	
29	S150651004	Ring E8	1	
30	B048049494	Screw M6X16	2	
31	BXF8449009	Thread trimmer cam	1	
32	BXF8732009	Spacer 4.8	4	
33	BX85874009	Screw M6X10	4	
34	BXF8448009	L-adjusting connecting rod	1	
35	BXF8447009	Round joint assy R	1	
36	BXF8445009	Round joint assy L	1	
38	BXF8443009	Adjusting connecting rod	1	
39	B089040704	Nut M6	1	
40	BXF8442009	Nut M6, Left	1	
41	BXF8441009	Screw M6	2	
42	BXF8438009	T-trimmer connecting rod, R	1	
43	BXF8437009	T-trimmer connecting rod, L	1	
44	B093500298	Bolt M5X8	2	
45	208100006	Washer M5	2	
46	BXF8465009	Shoulder screw M5	2	
47	BX03584809	Movable knife	2	
48	B962574009	Screw SM4.37-40X4.2	4	
49	BX03583009	Fixed knife	2	
50	B962571909	Shoulder screw SM2.38	2	
51	108500003	Nylon connector 12P	1	
52	001C63000	Ground wire assy	1	
53	B048500294	Screw M5X8	1	
54	W060402029	Bead band	1	
55	108400005	Bnc jacket	1	
56	036911002	Needle	2	

* The part circled by [] is supplied in complete set.

16. THREAD WIPER MECHANISM D3

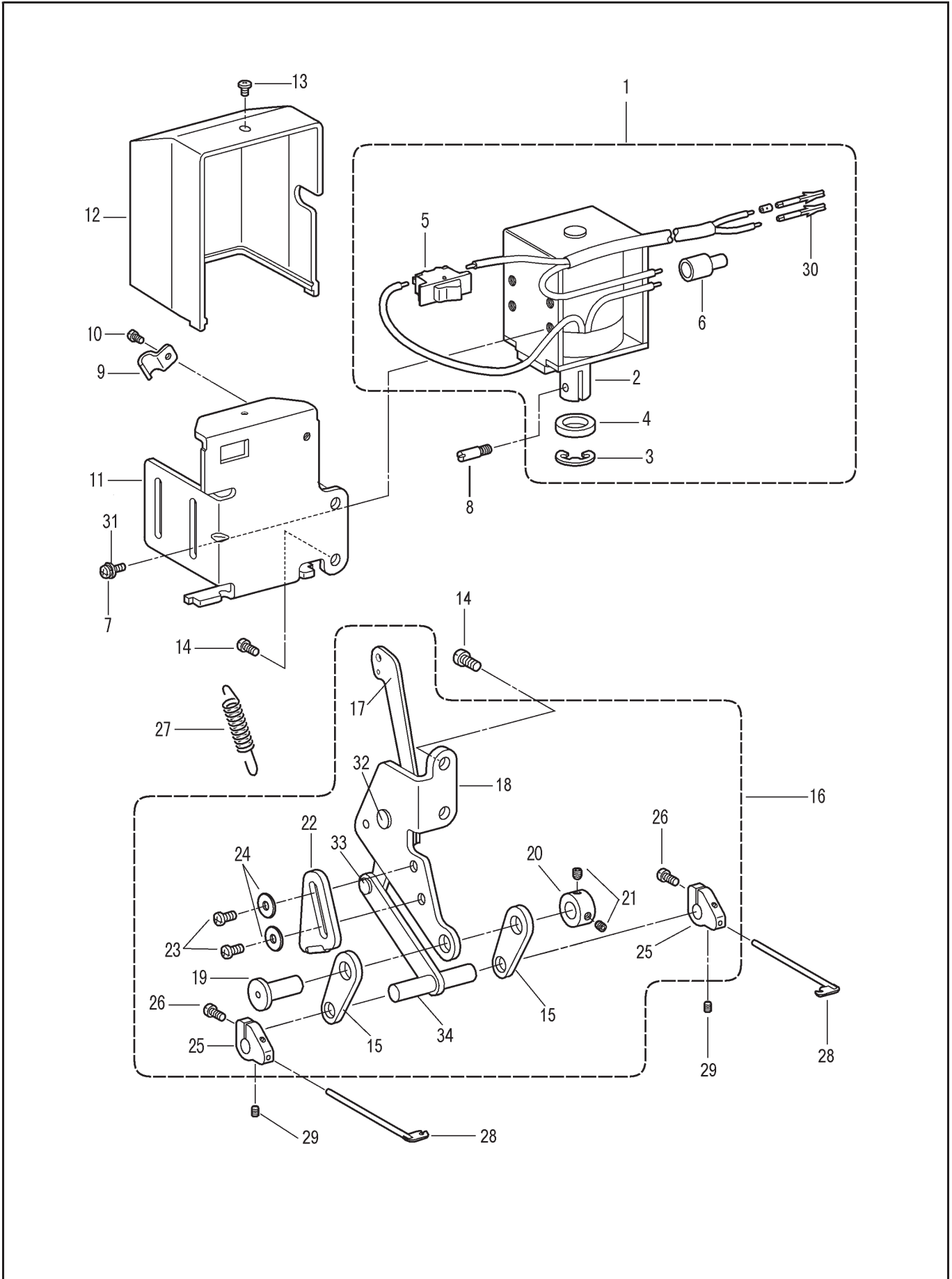

16. THREAD WIPER MECHANISM D3

No.	Ref.No.	Description	Qt	Note
1	BXF8420009	Thread wiper solenoid assy	1	
2	B962599009	Plunger	1	
3	B062010768	Retaining ring E9	1	
4	BX72684000	Plunger rubber	1	
5	BX08446009	Thread wiper switch	1	
6	BX08445000	Terminal connector	1	
7	S150237006	Screw M4X8	4	
8	B962564009	Pin	1	
9	B960463909	Cord holder	1	
10	B048600494	Screw M4X6	1	
11	BXF8378009	Solenoid holding plate	1	
12	BXF8414009	Solenoid cover	1	
13	B040600594	Screw M4X5	1	
14	B048509094	Screw M5X10	4	
15	BX03561909	Thread wiper link	2	
16	BXF8428009	Thread wiper solenoid assy	1	
17	BXF8425009	Transter plate	1	
18	BXF8427009	Solenoid link	1	
19	BX03562009	Pin	1	
20	BXF8506009	Set screw collar	1	
21	B098500574	Screw M5X5	2	
22	216M00005	Stopper	1	
23	B048500294	Screw M5X8	2	
24	B085050874	Washer 5	2	
25	BX03558009	Thread wiper support	2	
26	B048449898	Screw SM3.18-40X12	2	
27	BXF8426009	Spring	1	
28	BX03557009	Thread wiper	2	
29	BX03686009	Screw SM3.18X4	2	
30	036911002	Needle	2	
31	208100007	Washer4	4	
32	BX03562009	Pin	1	
33	BX03563009	Nail	2	
34	BX03564009	Connecting rod assy	1	

* The part circled by □ is supplied in complete set.

17. QUICK REVERSE MECHANISM D3

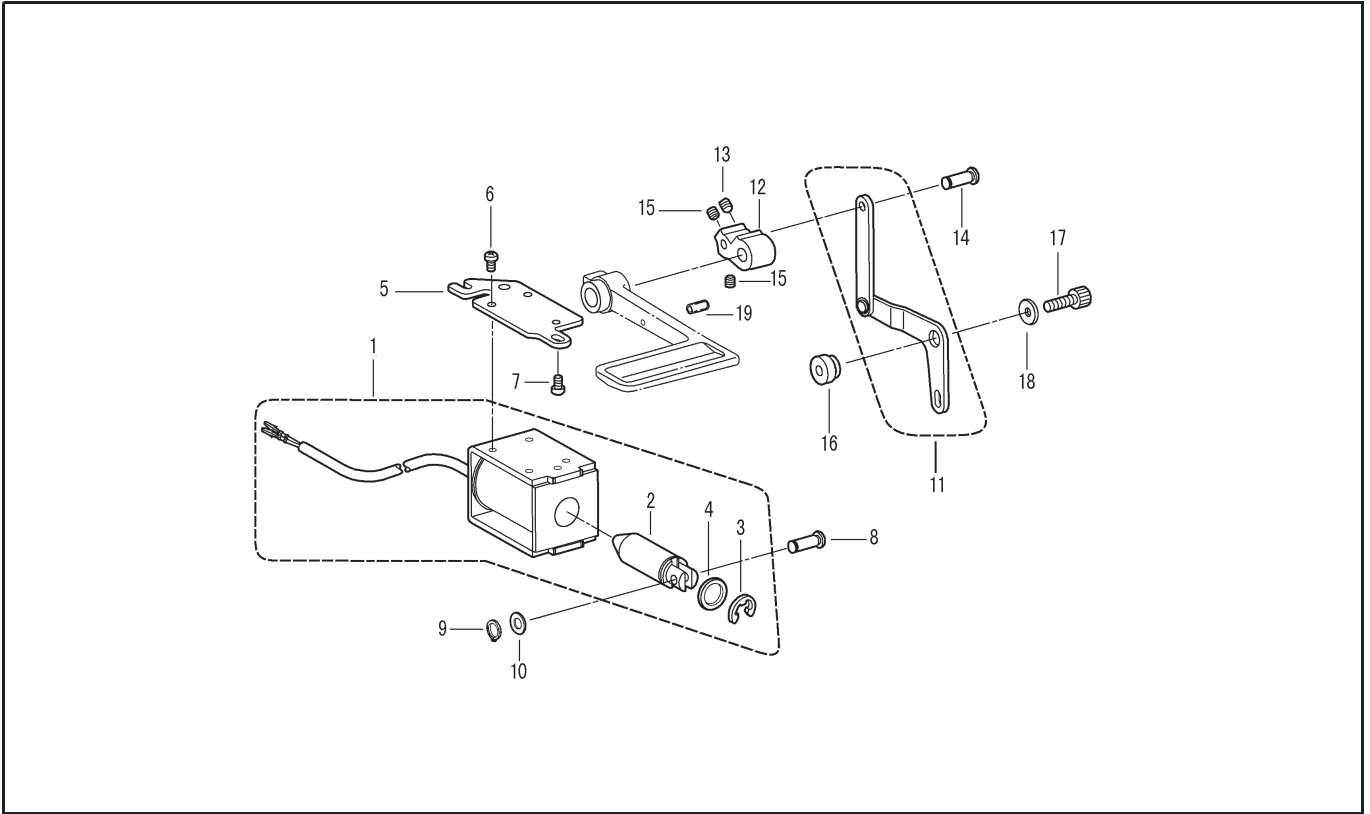

18. QUICK REVERSE SWITCH MECHANISM D3

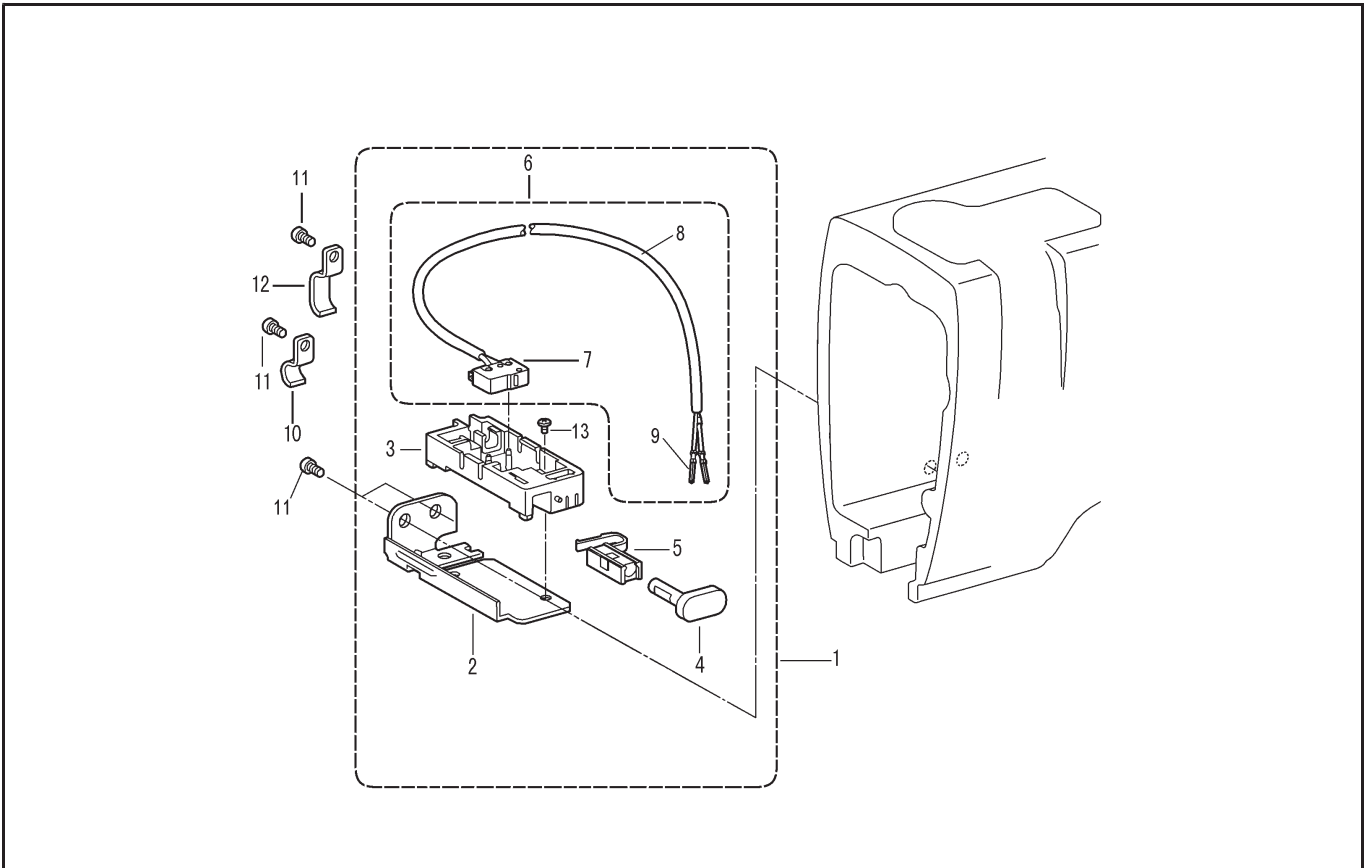

17. QUICK REVERSE MECHANISM D3

No.	Ref.No.	Description	Qt	Note
1	BXF7038009	Quick reverse solenoid assy	1	
1-1	BXF7037009	Quick reverse solenoid	1	
2	B956381009	Solenoid	1	
3	B956370009	Retaining ring E15	1	
4	B956379000	Rubber stopper	1	
5	BXF8575909	Solenoid bracket	1	
6	B048500294	Screw M5X8	3	
7	B048049094	Screw M6X10	2	
8	BXF8118009	Pin	1	
9	W120607004	Retaining ring C6	1	
10	B957972009	Washer 6.5	1	
11	BXF8574009	Solenoid lever assr	1	
12	BXF8560009	Quick reverse lever	1	
13	S150225003	Screw M6X10	2	
14	BXF8118009	Pin	1	
15	B098040474	Screw M6X6	2	
16	BXF8571009	Solenoid lever shaft	1	
17	B092048078	Screw M6X20	1	
18	B961015001	Washer 6	1	
19	B957978000	Nylon tube L=13.5	1	

18. QUICK REVERSE SWITCH MECHANISM D3

No.	Ref.No.	Description	Qt	Note
1	BXF8422009	Reverse switch assy	1	
2	BXF8830009	Reverse switch bracket	1	
3	BX76829000	Reverse switch bracket	1	
4	BX78106000	Actuator	1	
5	BX78105000	Reverse switch spring	1	
6	216M10300	Switch assy	1	
7	036830004	Switch	1	
8	216M00007	Reverse actuator wire	1	
9	036911002	Needle	2	
10	BXF8421009	Cord holder	1	
11	B048500494	Screw M5X6	4	
12	BXF9722009	Cord holder	3	
13	B040700404	Screw M3X6	1	

* The part circled by [] is supplied in complete set.

19. MOTOR AND SAFETY SWITCH D3

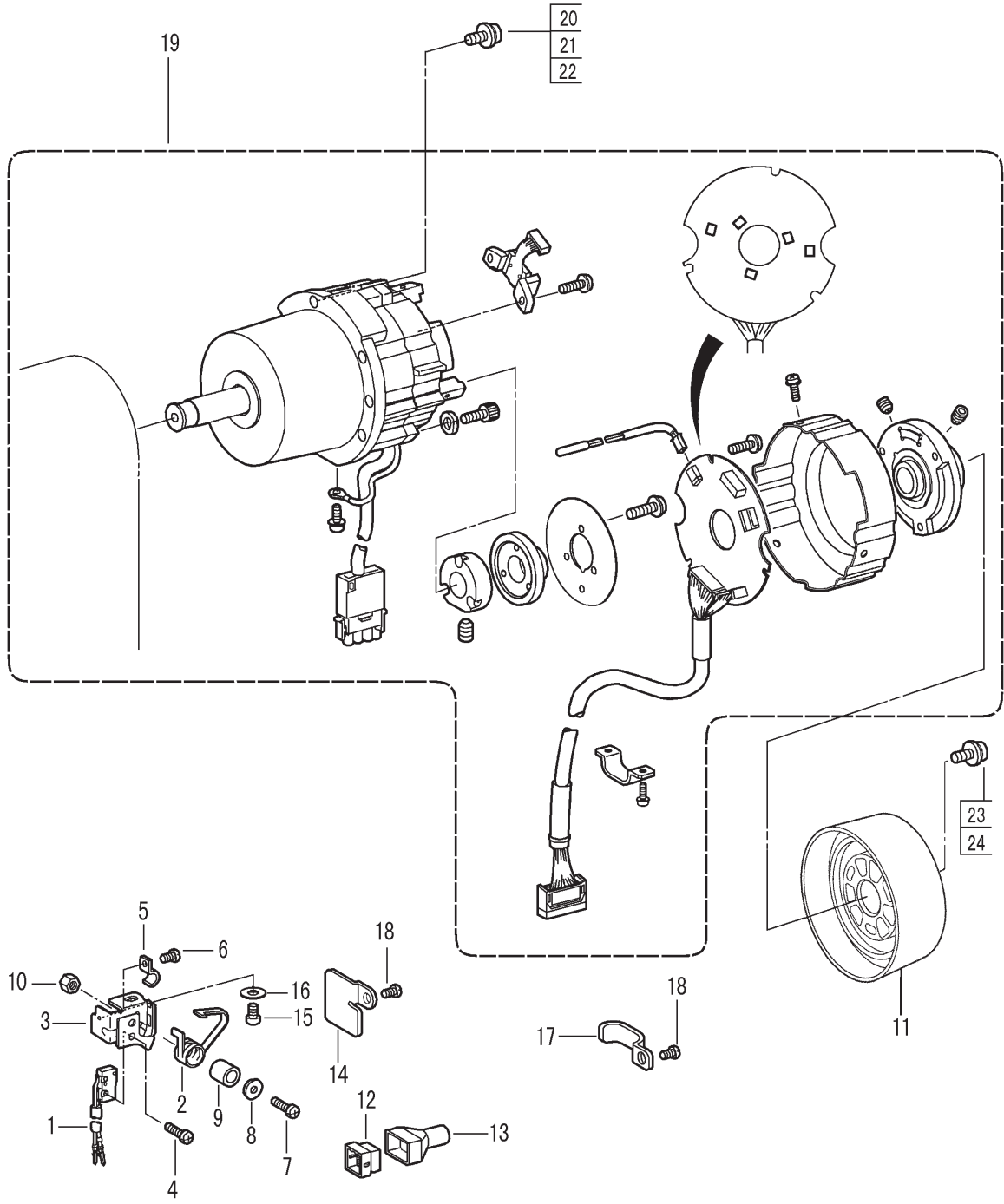

19. MATOR AND SAFETY SWITCH D3

No.	Ref.No.	Description	Qt	Note
1	BXF9725009	Micro switch assy	1	
2	216M00003	Switch plate spring	1	
3	BXF8424009	Switch base	1	
4	S4B1503009	Screw M2X8	2	
5	B960463909	Cord holder	1	
6	B048600494	Screw M4X6	1	
7	B048609894	Screw M4X12	1	
8	B084060874	Washer 4	1	
9	216M00004	Spacer	1	
10	B089600704	Nut M4	1	
11	BXF6060009	Pulley	1	
12	217100032	Nylon connector 4p	1	
13	217100026	Cap	1	
14	BXF8423009	Cord holder	1	
15	B048040298	Screw M6X8	1	
16	B085040974	Washer S6	1	
17	BXF8398009	Cord holder	1	
18	B048500294	Screw M5X8	2	
19		Motor assy	1	
20	B048509294	Screw M5X18	5	
21	B082050864	Washer 5	5	
22	B084050974	Washer 5	5	
23	B040609094	Screw M4X10	3	
24	230100013	Washer	3	

* The part circled by [] is supplied in complete set.

20. BOBBIN WINDER MECHANISM

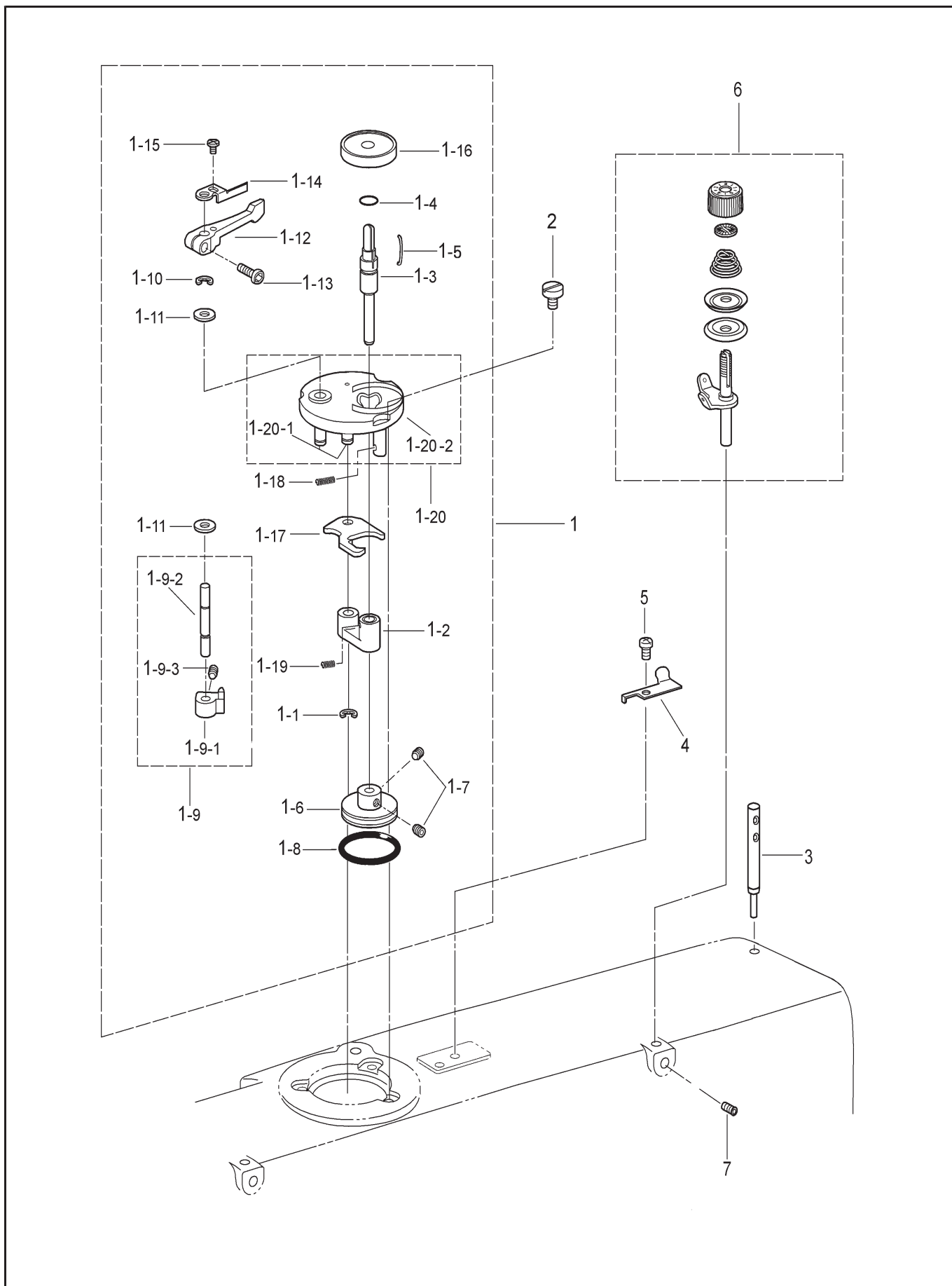

20. BOBBIN WINDER MECHANISM

No.	Ref.No.	Description	Qt	Note
1	BXF9139909	Bobbin winder unit	1	
1-1	B062060768	Retaining ting E4	1	
1-2	BXF9135009	B-winder shaft support assy	1	
1-3	BXF9132009	Bobbin winder shaft	1	
1-4	217102002	O ring	1	
1-5	217102001	Spring	1	
1-6	BXF9120009	Bobbin winder wheel	1	
1-7	S150224025	Set screw M4x6	2	
1-8	BX85321000	O ring	1	
1-9	BXF9129909	Rubber ring 29	1	
1-9-1	BXF9128909	Bobbin presser cam assy	1	
1-9-2	BXF9127009	Bobbin presser cam	1	
1-9-3	S150224026	Set screw M5x5	1	
1-10	B062060768	Retaining ring E4	1	
1-11	B085040974	Washer plain S6	2	
1-12	217100042	Bobbin presser arm	1	
1-13	S150237044	Set screw M4x12	1	
1-14	BXF9125009	Bobbin presser	1	
1-15	S150217018	Set screw M4x5	1	
1-16	217100033	Bobbin support	1	
1-17	BXF9121009	Bobbin winder lever	1	
1-18	BXF9110909	Spring	1	
1-19	BXF9119009	Spring	1	
1-20	BXF9138009	Bobbin winder support assy	1	
1-20-1	BXF9136009	Bobbin winder support shaft	1	
1-20-2	BXF9137009	Bobbin winder support	1	
2	BXF9118909	Set screw	3	
3	BXF9751009	Spool pin	1	
4	BXF9740909	Knife	1	
5	B048500494	Set screw M5x6	1	
6	BXF9116009	Bobbin winder tension assy	1	
7	B098500574	Set screw M5x5	1	

* The part circled by [] is supplied in complete set.

21. AUTOMATIC FOOT LIFTER MECHANISM

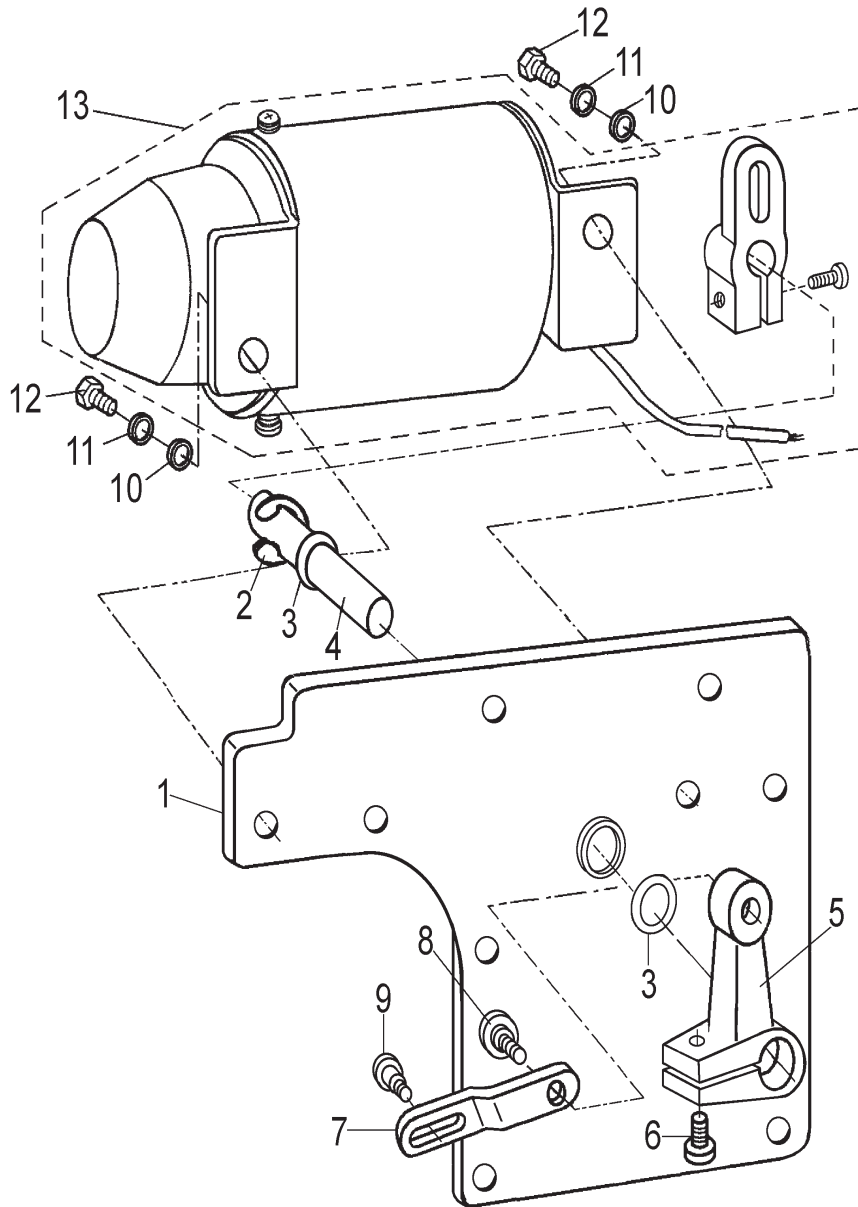

21. AUTOMATIC FOOT LIFTER MECHANISM

No.	Ref.No.	Description	Qt	Note
1	216XA1000	Back plate	1	
2	S150651004	Retaining ring 8	1	
3	S150633003	Washer 10	2	
4	216XA0002	Shaft	1	
5	216XA0001	Link crank	1	
6	S150220040	Screw M5x12	1	
7	216XA0003	Link	1	
8	216XA0004	Screw M6	1	
9	216XA0005	Screw M5	1	
10	B085040774	Washer 6	2	
11	B082040864	Washer spring 6	2	
12	S150258005-d	Screw M6x12	2	
13	108C03000	Foot lifter solenoid	1	

* The part circled by [] is supplied in complete set.

22. Accessories

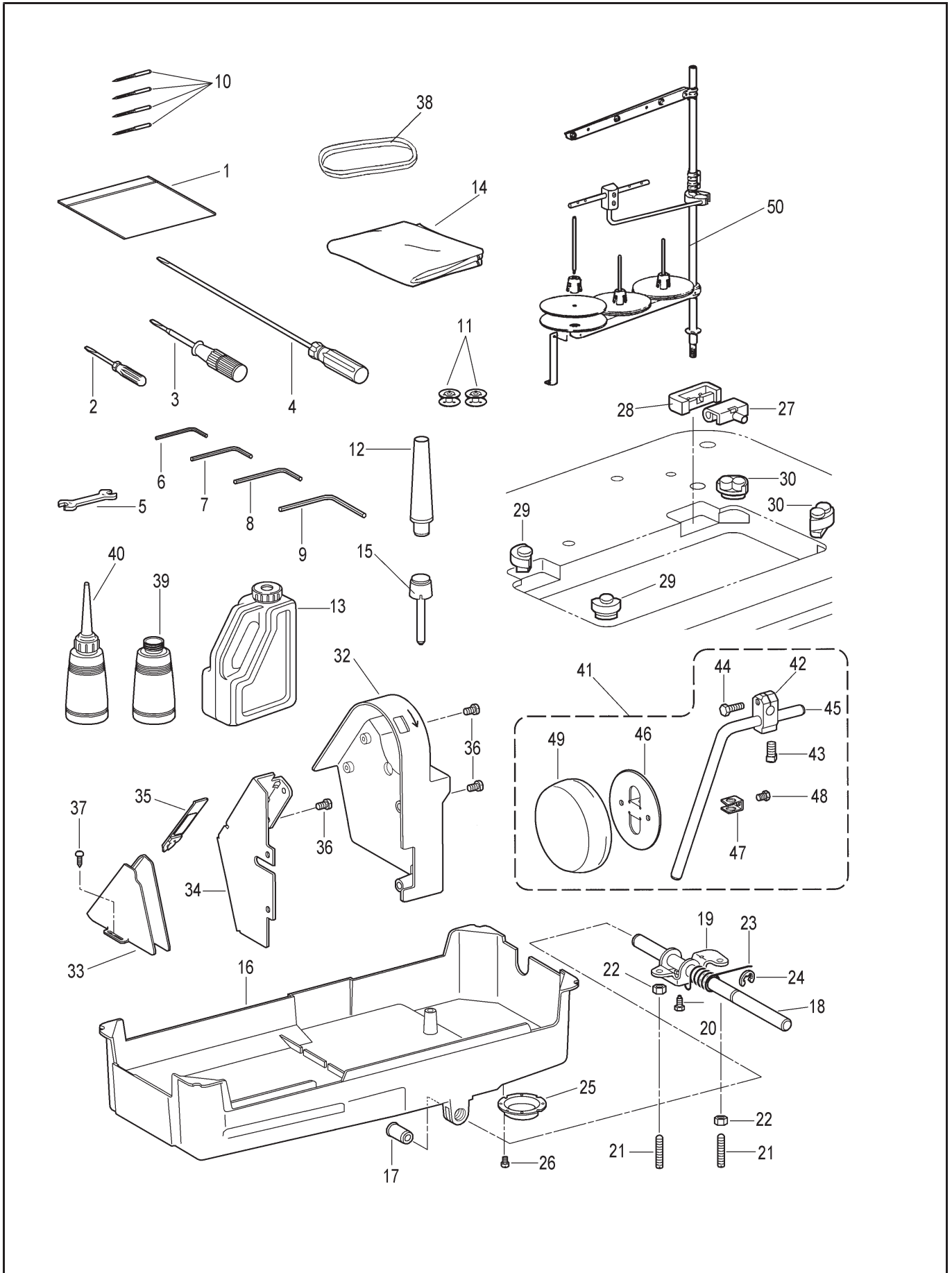

22. Accessories

No.	Ref.No.	Description	Qt	Note
1	W060302054	Accessory bag	1	
2	W050102048	Screw-driver	1	
3	B992273009	Screw-driver	1	
4	W050102046	Screw-driver	1	
5	B900223009	Wrench 8X9	1	
6	W050102034	Hexagonal wrench 2	1	
7	W050102040	Hexagonal wrench 2.5	1	
8	W050102035	Hexagonal wrench 3	1	
9	W050102037	Hexagonal wrench 5	1	
10	058310010	Needle DPX5 14#	4	For M
	048200005	Needle DPX5 18#	4	For H
11	BX09182959	Bobbin	2	
	BX01825059	Bobbin	2	
12	022900040	Head rest	1	
13	W050202009	Oil tank assy	1	
14	W060302076	Head cover	1	
15	B965537009	Knee lifter complying bar	1	
16	BXF8418909	Oil pan	1	
17	B961532000	Bush	2	
18	BXF8528009	Knee lifter shaft	1	
19	BXF8510009	Knee lifter	1	
20	BX85766009	Bolt M6	1	
21	BX85635009	Screw M6X19	2	
22	B089040704	Nut M6	2	
23	BX95221009	Twist spring	1	
24	B964817009	Retaining ring E10	1	
25	B957870909	Drain	1	
26	BX87692008	Screw M4X5	2	
27	B967228009	Head hinge	2	
28	B967190001	Rubber cushion	2	
29	BXF9148009	Head cushion	2	
30	BXF9147009	Head cushion	2	
32	216000016	Belt cover, U	1	Without direct drive
33	BXF8341009	Belt cover, D	1	Without direct drive
34	BXF8330909	Belt cover bracket	1	Without direct drive
35	BX73847009	Belt cover lid, L	1	Without direct drive
36	B048500294	Screw M5X8	6	Without direct drive
37	W050101039	Wood screw	2	Without direct drive
38	W050201017	Triangle belt	1	
39	W050202014	Oiler	1	
40	W050202013	Oiler assy	1	
41	BX72700009	Knee lifter assy	1	
50	BX03552701	Cotton stand assy	1	

* The part circled by □ is supplied in complete set.

9 SERIES DOUBLE NEEDLE MACHINES

The instruction of the adjustment for the puller

1. Tension adjustment

Keep the tension of puller in minimum while making sure the cloth feeding smoothly. To turn the screw A in clockwise to increase the tension. To turn the screw A in anticlockwise to reduce the tension.

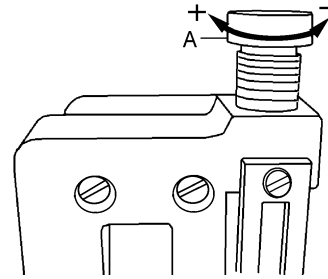

2. The adjustment for the cloth feeding

The cloth feeding for puller should be Adjusted according to the needle feeding. Loosen the screw B and move it down to increase the cloth feeding. Loosen the screw B and move it up to decrease the cloth feeding

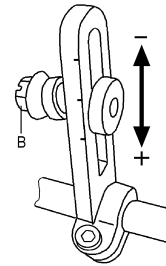

3. The Angle adjustment for puller

The user could adjust the angle of the puller by themselves. Loosen the screw C and D then take out the screw E. Turn the bracket F of the puller in horizontal direction and then disassemble the bracket and lower puller to achieve the straight cloth pulling

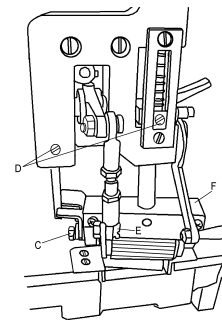

4. The adjustment for the height of puller

Put the spanner P down and make the puller in low position, adjust the screw H to make the gap of upper and lower puller with 0.5mm. And then fasten the nut G

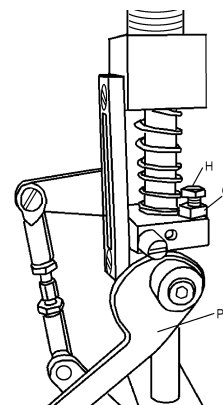
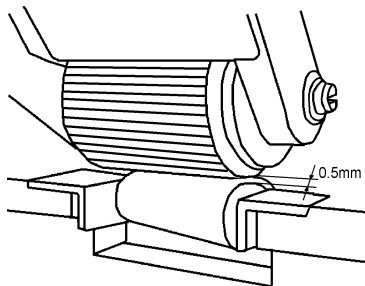

9 series special parts for puller system

No.	Ref.No.	Description	Qt.	Note
1	208R00001	Puller holder	1	
2	BXF8554009	Screw M6X25	4	
3	216Y00002	Block	1	
4	B048049494	Screw M6X16	2	
5	216Y00003	Puller holder (R)	1	
6	208R00004	Puller feeding shaft	1	
7	208R00005	Puller feeding shaft bush 1 (L)	1	
8	208R00006	Puller feeding shaft bush 2 (L)	1	
9	209200011	Collar	2	
10	B098600674	Screw M4X4	4	
11	208R00009	Puller cam	1	
12	BX85874009	Screw M6X10	2	
13	208R00010	Puller link	1	
14	B992156000	Bearing	1	
15	216Y00004	Adjusting link	1	
16	BXF8447009	Link assy R	1	
17	S120501011	Nut M6	3	
18	S120501015	Nut (L) M6	1	
19	208R00012	Puller crank (R)	1	
20	S150220004	Screw M5X14	2	
21	208R00013	Washer	2	
22	208R00014	Screw M6	1	
23	208R00015	Nut M6	1	
24	208R00016	Puller crank (L)	1	
25	B048500494	Screw M5X6	2	
26	BXF8448009	Length adjusting link assy	1	
27	208R00018	Screw M6	1	
28	208R00019	Puller connecting plate	1	
29	209200027	Screw	3	
30	216Y00007	Puller wheel holder	1	
31	208R00032	Puller wheel shaft	1	
32	197720007	Puller wheel bush (L)	1	
33	197720008	Puller wheel big bush (R)	1	
34	197720009	Puller wheel small bush (R)	1	
35	110E10003	Left washer	2	
36	S8A3103018	C – type stop ring 6	1	
37	208R00038	Inner bush	1	
38	J01540152	Nut M8	2	
39	208R00021	Screw	1	
40	208R00022	Puller wheel	1	
	208R00040	Puller wheel	1	
41	197720006	Inner bush	1	
42	S150866045	Bearing HFL2026	2	
43	208R00023	Stop plate	1	
44	197720016	Screw SM1/8"(3.18)X44X6	3	
45	197720010	Spring plate	1	
46	208R00033	Puller lower wheel holder 1	1	
	208R00044	Puller lower wheel holder(big)	1	
47	208R00034	Puller lower wheel holder 2	1	
	208R00045	Puller lower wheel holder(small)	1	
48	208R00035	Puller lower wheel	1	
	208R00037	Puller lower wheel	1	

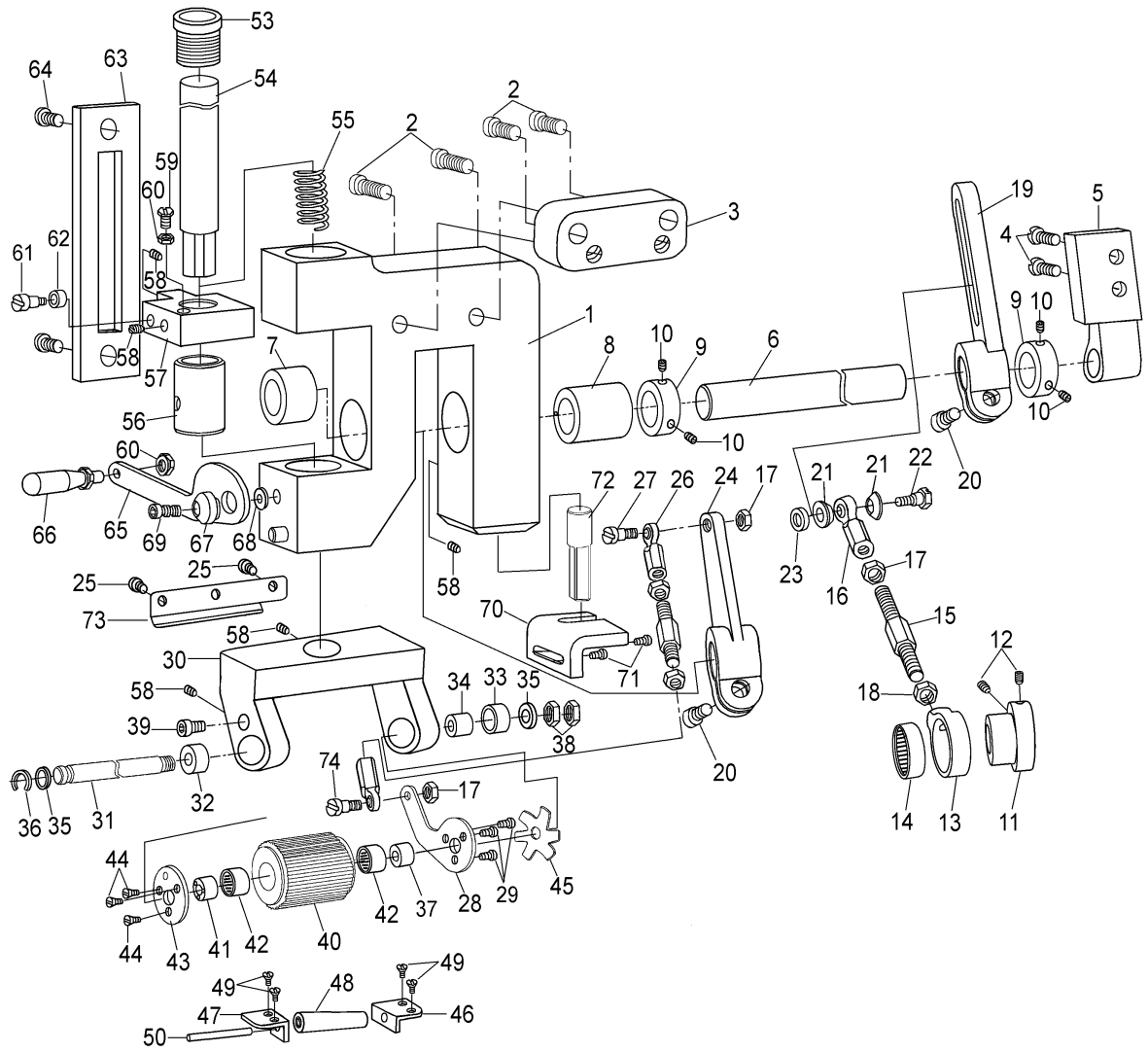

No.	Ref.No.	Description	Qt.	Note
49	209200017	Screw M4X6	4	
50	208R00036	Puller lower wheel shaft	1	
53	208R00024	Screw	1	
54	216Y00008	Presser bar	1	
55	208R00041	Presser bar spring	1	
56	208R00026	Presser bar bush	1	
57	208R00027	Presser bar holder	1	
58	B098500574	Screw M5X5	5	
59	S120104034	Screw M5X18	1	
60	B089500794	Nut M5	2	
61	197710003	Screw	1	
62	197710002	Lifting roller	1	
63	208R00042	Guide plate	1	
64	159300006	Screw	2	
65	208R00028	Spanner	1	
66	208R00039	T-type handle	1	
67	208R00029	Washer	1	
68	22T5-011	Washer	1	
69	S150220007	Screw M5X10	1	
70	208R00030	Stop block	1	
71	B048500294	Screw M5X8	2	
72	216Y00005	Stop bar	1	
73	216Y00006	Guard cover	1	
74	BXF8441009	Screw M6	1	

Machine's main technical data

Modle	Sewing speed	Max.Stitch length	Presser foot lift		Feed dog hight	Needle DPx5
			By hand	By knee		
GC9420M/MD/MD3	4000	4	7	13	1	#11-#16
GC9420H/HD/HD3	3000	5	7	13	1	#14-#22
GC9450M/MD/MD3	3000	5	7	13	1	#11-#16
GC9450H/HD/HD3	3000	5	7	13	1	#14-#22
GC9720M/MD/MD3	3000	7	7	13	1	#11-#16
GC9720H/HD/HD3	3000	7	7	13	1	#14-#22
GC9750M/MD/MD3	3000	7	7	13	1	#11-#16
GC9750H/HD/HD3	3000	7	7	13	1	#14-#22

Machine specifications

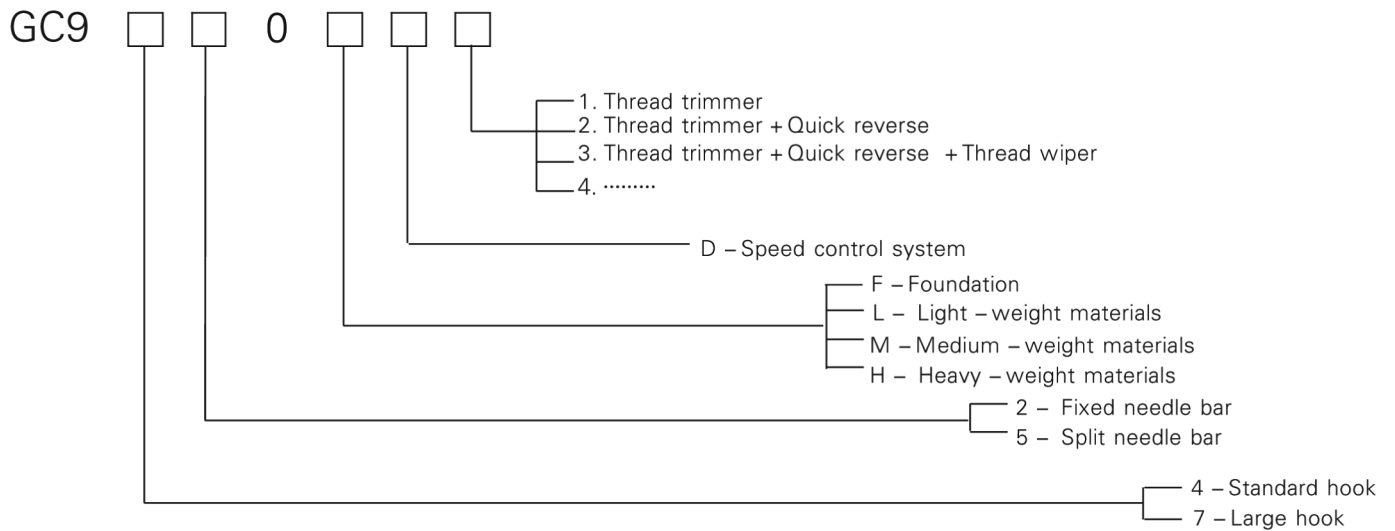

- Besides adjusting stitch, please laypeople don't debug or maintaine.
- Parts are subject to changes in design without prior notice.

XI'AN TYPICAL INDUSTRIES CO.,LTD.

Add: No.355 Taibai South Road,
 Xi'an, P.R.China-710068
 Tel :+86-29-88279091 88279150
 Fax :+86-29-88249715 88245215
 E-mail:typical@chinatypical.com
 Http:www.chinatypical.com
 Http:www.globalsources.com